The Pressure of Explosions. Experiments on Solid and Gaseous Explosives. Parts I. and II

J. E. Petavel

Phil. Trans. R. Soc. Lond. A 1906 **205**, 357-398

doi: 10.1098/rsta.1906.0011

Email alerting service

Receive free email alerts when new articles cite this article - sign up in the box at the top right-hand corner of the article or click [here](#)

To subscribe to *Phil. Trans. R. Soc. Lond. A* go to: <http://rsta.royalsocietypublishing.org/subscriptions>

XI. *The Pressure of Explosions.—Experiments on Solid and Gaseous Explosives. Parts I. and II.*

By J. E. PETAVEL.

Communicated by Professor ARTHUR SCHUSTER, F.R.S.

Received August 18,—Read November 16, 1905.

[PLATE 21.]

CONTENTS.

	Page
Introduction	358
PART I.	
METHODS AND APPARATUS.	
Explosive pressure gauges	359
Maximum pressure gauge	359
Recording manometer	361
Chronograph	364
Explosion chambers	365
Spherical explosion chamber	366
Cylindrical enclosure	368
Firing plug	368
Standard gauges	368
Valves and connections	369
PART II.	
EXPERIMENTAL INVESTIGATION OF THE EXPLOSIVE PROPERTIES OF CORDITE.	
General shape of the curves	373
Effect of the diameter of cordite	374
Effect of the enclosure	379
Relation of pressure to gravimetric density	384
Distribution of the explosive	386
APPENDIX: Tables of numerical results	390–398
VOL. CCV.—A 397.	30.12.05

LIST OF FIGURES.

No.	Page
1. Maximum pressure gauge	360
2. Recording manometer diagram	362
3. Recording manometer drawing	363
4. Chronograph camera	364
5. Spherical explosion chamber	366
6. Cylindrical explosion chamber	368
7. Firing plug	369
8. Valve and cone connections	370
9. Effect of ignition by oxyhydrogen and by gunpowder compared	372
10. Typical time pressure curve resulting from the explosion of cordite in a closed vessel	373
11. Variation of rate of explosion with the size of cordite used, gravimetric density 0·10	374
12. Variation of rate of explosion with the size of cordite used, gravimetric density 0·15	375
13. Effect of the gravimetric density and the diameter of the explosive on the time required to reach the maximum pressure	375
14. Rate of rise of pressure for cordite of the smallest diameter	377
15. Effect of the shape of the enclosure on the maximum pressure developed by cordite of large diameter	380
16. Effect of the dimensions of the enclosure on the rate of cooling of the products of combustion	381
17. Variation of maximum pressure with gravimetric density	384
18. Diagram illustrating the action of the explosion wave which is set up when the explosive is unevenly distributed	386
19. Variation in the rate of combustion and maximum pressure produced by a non-uniform distribution of the charge for cordite of 0·475 inch diameter	389
20. Variation in the rate of combustion and maximum pressure produced by a non-uniform distribution of the charge for cordite of 0·175 inch diameter	389

INTRODUCTION.

THE scientific treatment of this question may be said to date from the researches of Count RUMFORD who, at the end of the eighteenth century, devised the first apparatus by which explosive pressures could be estimated with some degree of approximation.

During the past century the natural fascination of the subject, and the importance of the problems involved, attracted many of the ablest scientific minds. Several have made the study of explosions the object of their life work.

In the short space available, an adequate historical epitome is unfortunately impossible. A mere enumeration of the names with which we shall most frequently have to deal must therefore suffice.

Our knowledge of the behaviour of solid explosives is due principally to the brilliant work of NOBLE in this country, and of BERTHELOT and VIEILLE abroad. With regard to explosive gaseous mixtures, the exhaustive work of LE CHATELIER and MALLARD in Paris, of DIXON in Manchester, and CLERK in London, is familiar to all.

At first sight it may appear to be over ambitious on the part of the author to attempt to add to the edifice built up by such able investigators. Closer consideration will, however, show that there is a gap in the structure ready to be filled by the small stone which he has quarried out.

In the case of solid explosives, thanks to NOBLE'S crusher gauge, the actual maximum pressure attained can be accurately measured. The mechanism of the explosion itself and the rate at which the pressure rises from the moment of ignition need, however, further investigation.

For gaseous explosives the same criticism holds true, more especially for mixtures which are highly compressed before they are fired. The first case has a bearing on all ballistic problems, the second provides some of the data necessary to the designers of the modern gas engine, and thus both are of considerable practical, as well as scientific importance.

PART I.—METHODS AND APPARATUS.

Explosive Pressure Gauges.

At the time this research was started, some six years ago, there was no instrument by means of which the variation of pressure during the course of such explosions could be satisfactorily recorded. Numerous attempts have been made, but without success, to reduce the moment of inertia of the existing types of recording manometers sufficiently to make them of service for this work. The natural period of oscillation, however, invariably proved to be too slow. In consequence, the curves traced out did not record the rise of pressure in the enclosure, but merely the vibrations set up in the mechanism of the gauge by the sudden shock to which it was subjected. To design a satisfactory instrument it was, therefore, necessary to start *ab initio*. Before, however, the work could be carried out, some further knowledge of the conditions prevailing during the explosion was necessary, and this more especially in the case of highly compressed gaseous mixtures, the behaviour of which was at the time practically unknown.

Maximum Pressure Gauge.

For this work a gauge was employed the construction of which will easily be understood from the drawing given in fig. 1. In principle the apparatus is the same as that used by BUNSEN, and consists of a piston closing an aperture in the explosion chamber, the piston lifting if the pressure of the explosion rises above the load for which it is set.

To reduce the inertia to a minimum, the weights, used in BUNSEN'S apparatus, are replaced by a gaseous pressure. The moving part consists of a double-headed piston

(P, p), the smaller end of which (p) is exposed to the force of the explosion, while the larger end (P) closes a cylinder filled with gas at a known pressure. The piston,

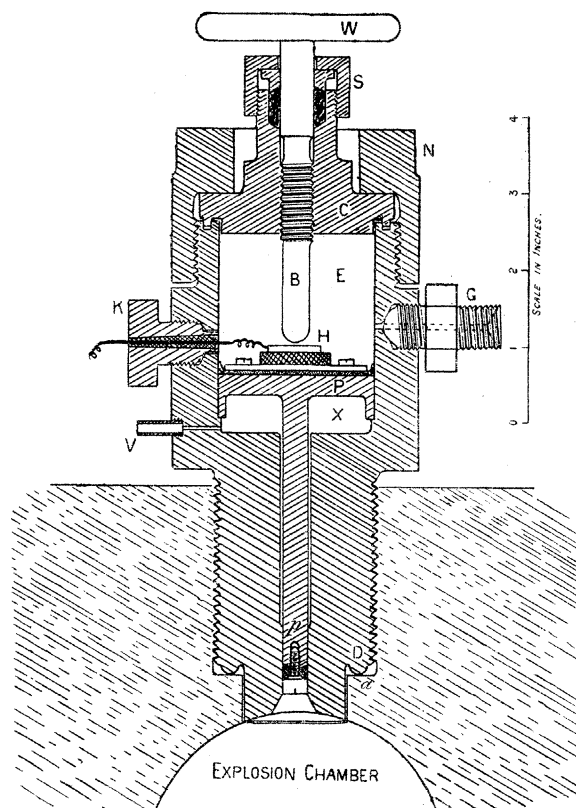

Fig. 1. Explosion gauge. (Maximum pressure indicator.)

The gauge consists of a double-headed piston, P, p . The smaller head p is exposed to the pressure of the explosion, which is counterbalanced by a fixed gaseous pressure acting on the larger head P . The ratio of the two areas (and therefore of the two pressures when in balance) is fifty to one in the case of the gauge illustrated in this drawing. The lift of the piston is limited to about one hundredth of an inch, the distance of the stop B being adjusted by means of a fine screw. The piston on lifting closes an electric circuit and works an indicator. S is the stuffing box through which the stop B passes, C the cover of the cylinder in which the piston P works; it is held down by the nut N . G is the gas inlet by means of which the space E is connected to a source of supply of gas under pressure and to a gauge. K is the plug through which the electric connection to the insulated contact-piece H is made. To prevent back pressure, which might arise through leakage past either of the leathers, the space X is connected with the atmosphere by means of the vent V .

on lifting, closes an electric circuit and works an indicator. To ensure rapid action, the travel of the piston is limited to about a hundredth of an inch.

Two such instruments were constructed. The first, for pressures up to 100 atmospheres, had a ratio of 4 to 1; in the second (shown in fig. 1), intended for use up to 1000 atmospheres, the ratio of the areas of the two sides of the piston was 50 to 1. Fairly satisfactory measurements of the maximum pressure were obtained by means of this apparatus.

With this instrument the work is very tedious, and no information is obtained as to the rate of combustion of the explosive. The experience gained during the course of the above preliminary investigation was, however, of the greatest use in the design of the final apparatus.

Recording Manometer.

The requirements for a reliable recording gauge are somewhat complex. In the case of gases, the explosive pressures to be dealt with range from 100 to 800 atmospheres; in the case of solid explosives it was desirable to extend the research to pressures of 2000 atmospheres, or above. The combustion of several gaseous mixtures is much more rapid than that of the fastest explosives used in ballistics, and the time period of a recorder designed for this work must, therefore, be exceptionally small.

Before passing on to a description of the instrument it may be well to recall in a few words the law which governs the time period of vibrating bodies.

If A represent the force required to produce unit deflection of the vibrating system, W the weight of the moving parts, the time period will be

$$= 2\pi \sqrt{\frac{W}{Ag}}.$$

We have, therefore, two variables at our disposal, namely, the weight of the moving parts and the controlling force. The former must be made a minimum, the latter a maximum.

In most instruments where a short period is desirable, the strains to which the parts are subjected are very small, and the desired result is obtained by decreasing the size of all moving parts, and using, wherever possible, materials of low density. This method is employed in the case of all oscillographs, telegraph recorders, phonograph receivers, galvanometers, &c.

In the present case, the instrument having to withstand pressures of 20,000 or 30,000 pounds per square inch, applied with extreme suddenness, strength becomes a condition of vital importance, and steel is the only material which will withstand the strain. We cannot, therefore, use materials of small density, neither can we reduce the dimensions of the moving parts below a certain limit.

It is thus evident that we must have recourse to the second variable factor to secure the short time period which is necessary. As we have seen above, the controlling force brought into play per unit length of motion must be as great as possible. In other words, we must use the stiffest spring we can obtain.

The stiffness of a spring will vary with the material of which it is made and with its shape, increasing as the shape approaches more nearly to that of a solid bar subjected to longitudinal strain. This bar can be made as short as may be desired

and, in theory, the time period of the system is only limited by the density of the material and by its modulus of elasticity.

In practice, however, the travel of the moving parts cannot be indefinitely decreased, for the deflections must remain of such dimensions as to be accurately measurable.

The following diagram illustrates the application of the principles we have just established to the construction of a recording instrument (see fig. 2).

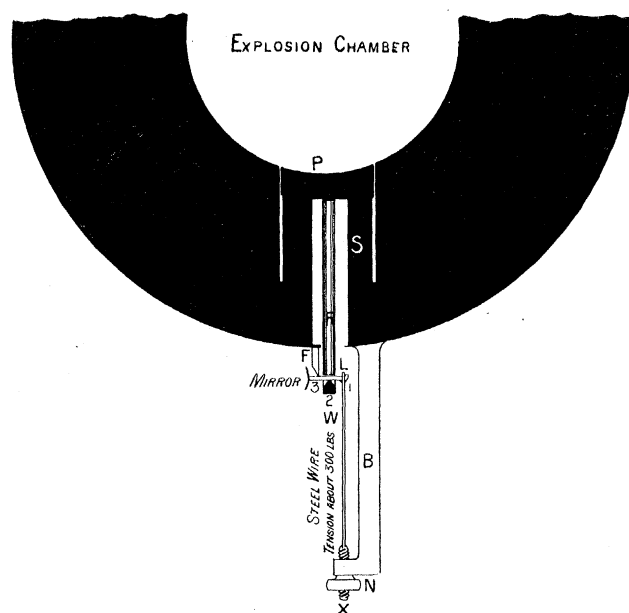

Fig. 2. Diagram of recording manometer.

A cylindrical groove is cut half through the walls of the enclosure. The upper part, P, of the cylinder thus obtained represents the piston of our indicator, and the lower portion, S, the spring. Under the pressure of the explosion the piston P will be forced outwards to an amount corresponding with the elastic compression of the material of which the spring is made. This motion is transmitted to the exterior by the rod R.

The lever L, supporting the mirror, rests on the fulcrum F at 3; it is kept against the knife-edge 2 of R by the tension of the wire W. The wire W is of considerable length, and is stretched almost to its limit of elasticity. The lever L can, therefore, follow the small advance of the rod R without greatly diminishing the tension of the wire W. The mirror focuses a point source of light on to a rapidly revolving cylinder, thus recording on a magnified scale the motion of the piston P.

It is not impossible that an indicator of this type would work in practice, but the deflection of the mirror, and, therefore, the scale of the records obtained, would be much too small. To increase the deflections, three modifications are necessary—the

spring S must be made longer, the ratio of its cross-sectional area to that of the piston must be decreased, and the knife-edges 2 and 3 be brought closer together.

In fig. 3 the design of the actual instrument is given, the lettering being the same as in the previous figure.

By means of the thread U the gauge screws into the explosion chamber, the end C of the piston being flush with the inside surface. An air-tight joint is formed by

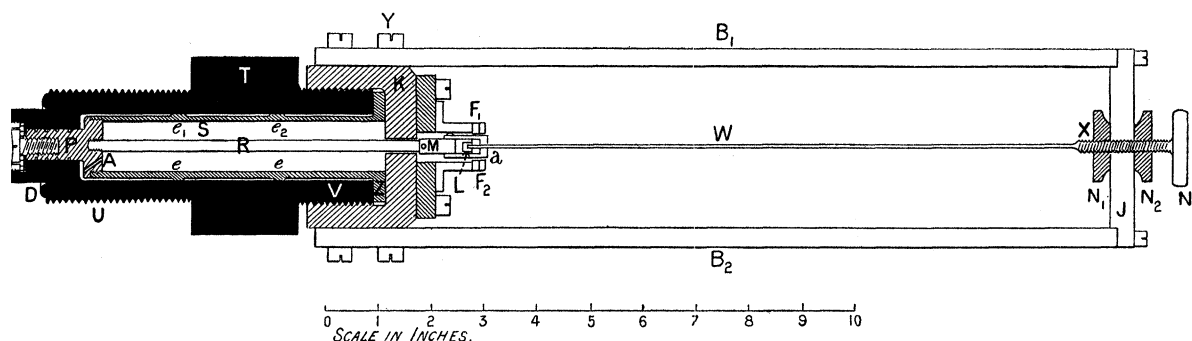

Fig. 3. Recording manometer.

the ring D on the manometer pressing against a flat ledge in the enclosure (see fig. 5, *a*). The end of the gauge from D to E is a good fit in the walls of the explosion chamber, and the joint is thus protected from the direct effect of the explosion.

The spring S, about 5 inches in length, is tubular in shape. To prevent any buckling it is made to closely fit the cylinder, in which it is contained, at two places, e_1 and e_2 . The spring is fixed at the outer end Z, being held in place by the nut K; at the inner end it is free and supports the piston P. The copper gas check used in the crusher gauge is replaced by a leather washer, attached to the piston by the screw C and to the fixed part of the gauge by the ring E. The end of the piston projects by about one-hundredth of an inch, and it can therefore move back, by this amount, without straining the leather.

The mirror (not visible in the figure) is carried by the lever L. This lever is so designed that the knife-edges 1, 2 and 3 (see fig. 2) are in the same plane, it being at the same time possible to bring the knife-edges 2 and 3 within one-hundredth of an inch of each other, should so great an amplification be found necessary. Up to the present, however, the distance has not been decreased below one-sixteenth of an inch, the scale obtained with this distance being found sufficiently large.

The actual working of this type of recorder has proved very satisfactory. Its time period is sufficiently small to allow records to be obtained not only of the curve of rise of pressure of the fastest cordite, but also of the rapid vibrations which modify the curve under certain conditions.*

* Captain BRUCE KINGSMILL has proposed the application of this gauge to ballistic work with a view to "indicating" a gun in much the same manner as we now indicate a steam engine. This suggestion, which might lead to valuable results, has, as far as I am aware, not yet been carried out in practice.

Chronograph.

Owing to the high speed required, the chronograph used for this work had to be specially designed. It is unnecessary to go into all the details of its construction. The ordinary methods were used to measure the velocity of the rotating drum and to ensure the constancy of speed during the course of an experiment.

When measuring the rise of pressure during an explosion, a linear speed of between 100 and 1000 centims. per second was used. For measuring the fall of pressure during the cooling of the products of combustion the driving mechanism could be geared down to give a linear speed of 5 or 10 centims. per second.

The drum of the chronograph can be easily detached and taken to the dark room, where the photographic film is wound on; it is then placed in a light-tight box. As explained in connection with fig. 4, this box is so arranged that the drum can be

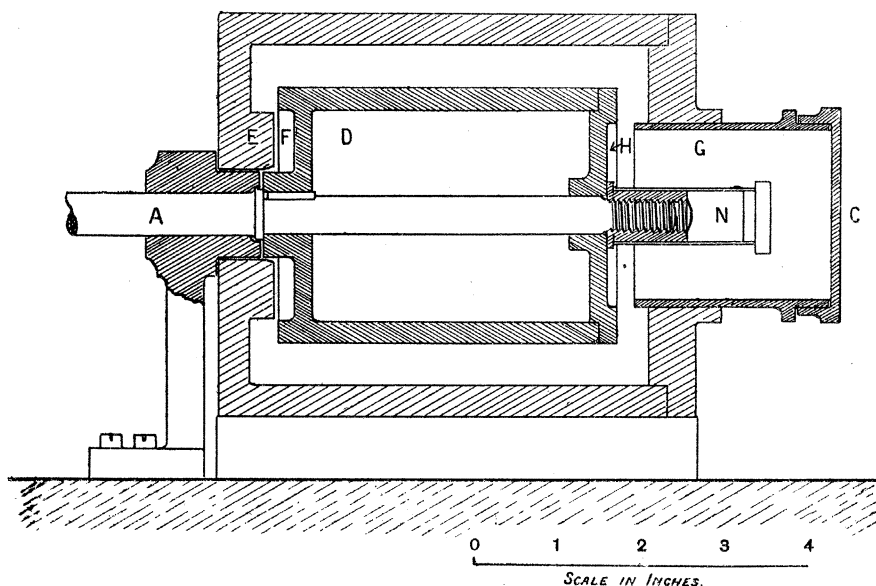

Fig. 4. Chronograph camera.

The drum *D* is shown fixed on the axle *A* of the chronograph. To remove the drum without exposing the film which is wound round it to the light, the camera is first moved a little to the right, causing the ring *E* on the camera to fit into the groove *F* of the drum. The brass tube *G* is next forced into the groove *H*; its cover, *C*, can then be removed and the nut *N* unscrewed. The camera, with the drum firmly held in it, can now be detached from the chronograph (by sliding it to the right) and taken to the dark room, where the film is developed and replaced by a fresh one.

fixed on to the axle of the chronograph in the full daylight without fogging the film. The box surrounding the revolving drum is pierced with a long and very narrow slit; this, in turn, is covered by a shutter, which is lifted immediately before the explosive is fired and closed again a second later, after the photograph has been taken.

Thanks to the above arrangement it is not necessary for the room in which the experiments are carried out to be absolutely dark. The mirror of the recorder is

illuminated by a straight-filament incandescent lamp, the image of the filament being focused on to the slit of the chronograph camera, forming a straight streak of light perpendicular to the axis of rotation. The beam of light is deflected to an amount proportional at each instant to the pressure in the explosion chamber and, travelling along the slit of the camera in a direction parallel to the axis of rotation, traces out a curve on the photographic film. The ordinates of this curve represent the instantaneous pressures, the abscissæ the times at which the said pressures existed.

A low-voltage high-candle-power lamp is used to illuminate the mirror, the comparatively thick filament of such a lamp giving correspondingly more intense illumination. At the moment of firing, the lamp is switched for a few seconds on to twice its normal voltage, and thus the strongly actinic light required is produced.

The recorder is calibrated by hydrostatic pressure before and after each set of experiments.

Explosion Chambers.

It is well known that the shape of the enclosure has a considerable effect on the behaviour of the explosive during combustion. On the other hand, the ratio of the internal surface to the total volume of the chamber determines to a large extent the rate at which the pressure will subsequently fall.

With a view of obtaining some further information on these questions, two explosion chambers were constructed having approximately the same volume, but differing largely in shape. The first, a sphere, offers the least possible cooling surface; whereas the second, a long narrow cylinder, has a surface more than twice as great.

One of the subjects of the research was to study the oscillations of pressure which are set up under certain conditions. In a long cylinder such oscillations are easily started, but in a small sphere the symmetrical shape and the short distance from wall to wall tend to equalise the pressure existing at each instant throughout the enclosure. Thus, in a spherical enclosure, the pressure rises usually without vibration and forms a smooth curve, the shape of which depends exclusively on the nature of the explosive used. In a long cylinder, however, the normal curve is modified by the distribution of the explosive, the method of firing, and various other factors.

Before designing these chambers, the relative advantages of solid metal and wire winding were fully considered. The latter construction, if properly carried out, adds considerably to the ultimate strength. A system of winding suitable for a spherical enclosure is, however, not easy to devise, and this fact, together with the ever important consideration of cost, led to the adoption of solid walls.

Mild steel was chosen as the material best suited to withstand the sudden impact of an explosion. The limit of elasticity, ultimate strength, and elongation of test pieces cut perpendicular to the direction of rolling were carefully determined before the forgings were machined.

Spherical Explosion Chamber.

The first explosion chamber is a nearly perfect sphere, 4 inches in diameter (see fig. 5). The measurements made in a plane passing through the axis of rotation

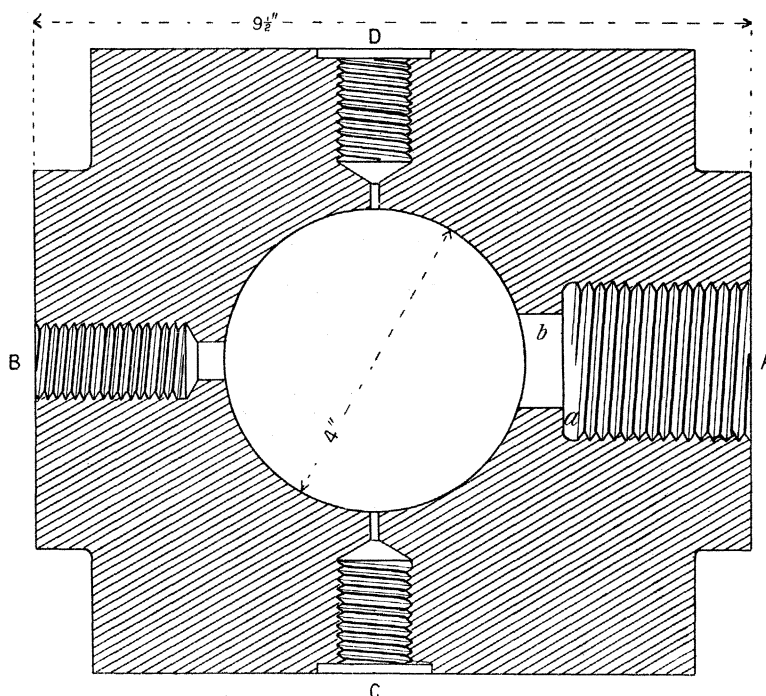

Fig. 5. Spherical enclosure.

The recording gauge screws in at A, the firing plug at B, and two valves at C and D respectively. The spigots, which are turned on the forging at either end (A and B), fit into a cast-iron stand, to which the enclosure is firmly bolted.

when in the lathe (*i.e.*, in the plane in which any variation from the spherical shape would be a maximum) showed that the greatest divergence from the mean diameter did not exceed one hundredth of an inch.

The cavity was cut out of a solid block of rolled steel through an opening only $1\frac{1}{4}$ inches diameter, a clever piece of engineering, for which I am indebted to Messrs. LENNOX and Co. Exceptional care was also taken to give the inner walls a smooth polished surface.

The internal volume of the cavity was redetermined by weighing the mercury required to fill it. From these determinations the diameter of the sphere is 10.20 centims. The volume is, therefore, 556 cub. centims. and the internal surface 327 sq. centims.

The minimum thickness of the walls is $2\frac{1}{8}$ inches, and the apparatus would doubtless withstand a pressure of 2000 atmospheres. As, however, the experiments had to be carried out in an ordinary laboratory, under conditions which would have rendered

the consequences of an accident disastrous, it was decided not to exceed half this limit. The second enclosure was alone used for higher pressures, it being, as we shall see, of stronger construction.

Apart from the effect of actual pressure, that of the sudden impact or blow given by the more rapid explosives has to be considered. As will be seen below, some mixtures of compressed coal gas and oxygen develop their full pressure in something like one ten-thousandth of a second and, in fact, occasionally detonate. It is difficult to estimate the actual strain produced by a force so suddenly applied.* When we consider that the present work comprised the repeated explosion of such mixtures, it will be seen that exact calculation becomes impossible. In all probability, during the course of the first few explosions of this kind the part of the material nearest the inner surface is strained to beyond its limit of elasticity, and therefore yields. In the case of steel, like the present, having a fair elongation, the first effect is actually to strengthen the enclosure; the inner layers of the steel having been thus permanently elongated are under an initial compression which will help them in resisting further deformation. Aided, however, by the extremely rapid variations of temperature, this effect will in time cause surface cracks. Under successive strains the cracks will deepen to an extent that may become dangerous. Being on the inner surface of the chamber, the extent of the damage cannot be clearly ascertained. In the present work this danger was guarded against by a method which, though perhaps somewhat crude, is at least easily carried out and, *faute de mieux*, may be considered satisfactory. On the outer surface of the enclosure a ring was accurately turned; the plane through the centre of this ring passes through the centre of the sphere and through the gas and mercury inlets: it therefore encircles the weakest portion of the enclosure. A large micrometer gauge was made, by means of which the diameter of this ring was from time to time measured. This micrometer will clearly show an increase of one three-thousandth of an inch on the 8-inch diameter, or a change of about one two-hundredth of one per cent.

Up to the present no variation of diameter has been detected, and it is reasonable to infer that the apparatus has not been strained to a dangerous extent.

A sectional drawing of the enclosure is given in fig. 5.

The recording gauge screws into A, the steel ring (D, fig. 3) pressing on to the ledge *a* and thus forming a joint. The end of the gauge fits closely into the neck *b* and protects the joint from contact with the heated gases. The firing plug fits into the aperture B.

When gaseous mixtures are to be tested, the two valves which screw into C and D are brought into use. The cavity is first filled with mercury through C and the gas is then forced in through D. As soon as the mercury has been driven out, the valve

* It is usual to take an instantaneous load as equivalent to twice the same statical load. In the present case, however, we have to deal with the momentum of the gas itself, which is travelling at an enormous speed.

C is closed and the pressure and composition of the mixture adjusted by means of the apparatus described below.

After each explosion the sphere is washed out first with a solution of caustic potash, then with distilled water.

Cylindrical Enclosure.

The cylindrical enclosure, shown in fig. 6, is also made of mild steel.

The dimensions are: external diameter 12·2 centims.; internal diameter 3·17 centims.; length of bore 69·64 centims. It has, therefore, a capacity of 550 cub. centims. and an internal surface of 709 sq. centims.—roughly speaking, the same

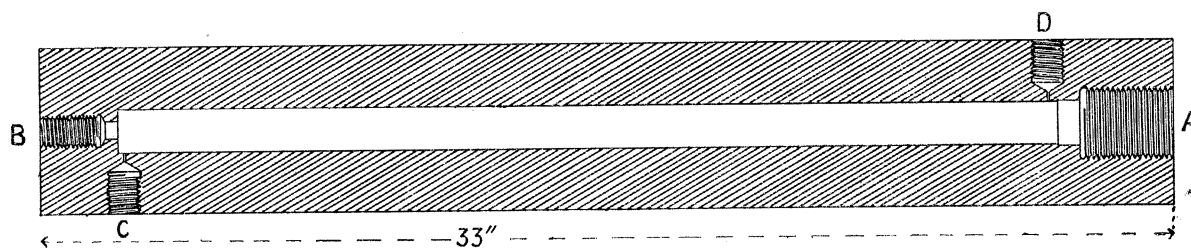

Fig. 6. Cylindrical enclosure.

The recording gauge screws in at A, the firing plug at B, and two valves at C and D respectively. The volume of this enclosure is nearly the same as that of the sphere, its surface 2·17 times as great.

volume as the sphere, but rather more than twice its surface. The various apertures are identical to those of the spherical enclosure and the gauges and other fittings can, therefore, serve for either apparatus. This cylinder has been used up to 2000 atmospheres and would doubtless be safe at a considerably higher pressure.

Firing Plug.

The design of the firing plug is clearly shown in fig. 7.

Standard Gauges.

A vast number of measurements of statical pressure had to be made during the course of the work, more especially for the part dealing with gases. For this purpose the connections were arranged so that the gauges could be easily interchanged, each one being used for the range over which it was most sensitive. To determine the initial pressure and composition of the gaseous mixtures, two independent sets of observations were always taken. The pressure was first roughly adjusted to the desired amount by means of direct-reading Bourdon gauges, then accurately measured by a standard gauge. A series of mercury columns were used for the lower pressures and manometers of the Cailletet type for the higher pressures. The various

small modifications introduced in the construction of the latter instrument, though they added to its reliability, are not of sufficient importance to warrant a more detailed description.

Three gauges of this pattern were in use, the first reading from 3 to 12 atmospheres, the second from 12 to 50, the third from 50 to 200.

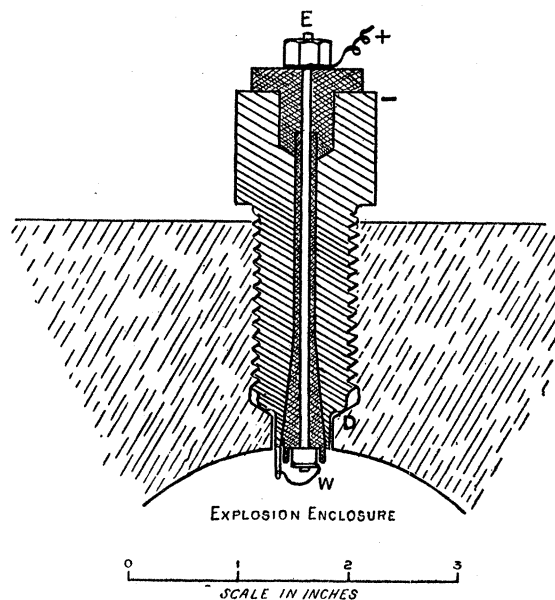

Fig. 7. Firing plug.

The insulation of the central conductor is cone-shaped, to prevent its being forced out by the pressure of the explosion. A small cartridge of fine gunpowder can, when required, be placed round the fine wire *W*. The gas-tight cone joint *D* is protected, in the usual manner, from direct contact with the flame by a projecting piece, which closely fits the aperture in the explosion chamber.

Valves and Connections.

The various valves by which the flow of the gas is regulated are of the type shown in fig. 8.

The gas inlet is at *A*, whereas *B* is connected to a gauge which indicates the pressures behind the valve. A fine screw-thread is cut on the spindle *S*. By turning the wheel *W* the conical end *F* of the spindle is lifted slightly from its seat and the gas flows to the part of the apparatus connected to *C*. To avoid any sudden rush of gas the spindle bears a slightly tapered prolongation, which nearly fits the outlet, and, therefore, several turns of the screw are necessary to give the full opening.

The many connections required throughout the apparatus are all cone joints of the type shown at *C*.

The female connection ends in a hollow cone, the angle being about 100 degrees. The male *D* is a cylinder of brass, an inch or two long, ending in a hemisphere, which is pressed into the cone by the nut *N*, the inner surface of which bears upon a ring *R*.

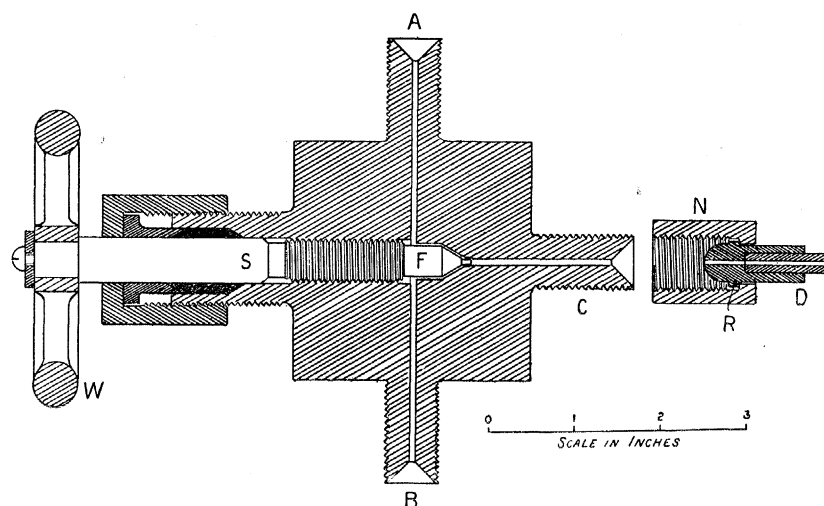

Fig. 8. Valve and connecting cone.

The numerous valves required during the present research were all substantially of the type shown in this figure, though varying considerably in external shape according to the use for which they were intended. The above design was used for the valves serving to regulate the initial pressure and composition of the mixture in the experiments on gaseous explosives. The apparatus is fixed firmly to the working bench by screws (not shown in figure) passing through the four corners of the metal block.

Into this cylinder the copper tube is soldered for a distance of about three-quarters of an inch. These cone joints are superior to the lead washer joints, inasmuch as they are easily made or disconnected, last indefinitely, and remain gas-tight under all pressures.

PART II.—EXPERIMENTAL INVESTIGATION OF THE EXPLOSIVE PROPERTIES OF CORDITE.*

The maximum pressure developed by explosives can be measured with considerable accuracy by means of the crusher gauge, which was devised some thirty-five years ago by Sir ANDREW NOBLE.† The classical work since carried out by this investigator is too well known to need a mention here. Attention may, however, be drawn to one of the more recent papers, in which NOBLE publishes the cooling curves of cordite and describes the instrument by which they were obtained.‡ The apparatus is in principle not unlike an ordinary steam engine indicator, but the spring is initially compressed by an amount corresponding to nearly the full pressure of the explosion, and is automatically released when this pressure has been reached. By this ingenious contrivance the violent oscillations of the spring, which would be set up by the explosion itself, are avoided, and a clear record of the rate of fall of pressure is inscribed.

* The explosive used in the course of this work was issued, by order of the Secretary of State for War, as representing the service cordite of the year 1902. Samples of three different sizes were included in the issue, the nominal sizes being 50/17, 20/17 and 3 $\frac{3}{4}$.

† 'Proc. Roy. Inst.,' vol. VI., p. 282, 1871; see also 'Phil. Trans. Roy. Soc.,' vol. 165, p. 49, 1875, and 'Phil. Trans.,' vol. 171, p. 203, 1880, &c.

‡ 'Proc. Roy. Inst.,' vol. 16, p. 329, 1900.

In ballistic tests the total energy imparted to the projectile is calculated from the readings of the Holden-Boulanger chronograph, and, in the case of specially constructed experimental guns, the Noble chronograph gives valuable information on the distribution of pressure within the gun itself.*

With regard to the more destructive explosives, such as blasting powders, dynamite, &c., their power is usually estimated by means of the Trauzl† lead block. At Woolwich this method has, however, been recently abandoned, an apparatus of the pendulum type being now in use.‡

By the above methods the maximum pressure and the rate of fall of the pressure, or at least the total energy, can in most cases be satisfactorily estimated.

Comparatively little information is, however, available with regard to the initial part of the explosion; *i.e.*, the behaviour of the explosive from the moment at which it is fired up to the time when it is fully consumed.

This point deserves further investigation, the action of the explosive during this period being no less important than the question of the maximum pressure attained.

It must be borne in mind that any structure, whatever its nature, will behave very differently according as it is exposed to a stress gradually applied, or is subjected suddenly to the same stress, or finally is submitted to violent oscillations of load.

In the case of a gun any abnormally rapid explosion gives rise also to another source of danger. The time elapsing between the ignition and the complete combustion of the charge may be insufficient to allow the inertia of the shot to be overcome and to move it through an appreciable distance. Should this occur, the products of combustion would be confined in an unduly small space, and the pressure would rise above the safe limit.

The study of the initial stage of the explosion for various powders has formed part of the researches carried out by the Service des Poudres et Salpêtres in Paris. The gauge first used by VIEILLE was a modification of the crusher gauge§, while of late years he has worked with a new type of spring manometer.||

In Germany, BICHEL, BRUNSWIG¶ and others have suggested that the properties of explosives should be determined by measurements made at relatively low pressures, the results being deduced by extrapolation. Careful work has been carried out by BLOCHMANN** under these conditions. The gravimetric densities †† used are from 0·01

* 'Report Brit. Assoc.,' Oxford, 1894, pp. 523-540.

† 'Ber. Int. Kong. Angew. Chem.,' Berlin, 1903, vol. II., pp. 299-303 and 462-465.

‡ Captain DESBOROUGH'S report. See '25th Report of H.M. Inspector of Explosives.'

§ 'Comptes Rendus,' vol. 112, p. 1052, 1891.

|| 'Mémorial des Poudres et Salpêtres,' vol. XI., pp. 157-210, 1902; see also 'Comptes Rendus,' vol. 115, p. 1268, 1892.

¶ 'Ber. Int. Kong. Angew. Chemie,' vol. II., pp. 282-299, 1903.

** 'DINGLER'S Poly. Journ.,' vol. 318, pp. 216 and 332, 1903.

†† Gravimetric density is defined as the ratio of the weight of the charge to the weight of that volume of water which would fill the enclosure; it is, therefore, numerically equal to the specific gravity of the gas produced when the explosive is fired.

to 0·02 and the maximum pressures recorded below one half ton per square inch. It is necessary to point out that such a method may not infrequently lead to most serious errors.

Finally, it is generally understood that, in connection with this subject, numerous experiments have been carried out at Woolwich under the direction of Major HOLDEN, but no results have as yet been published.

Experimental Work.

A preliminary question to be decided, before starting the series of experiments, referred to the method of ignition. The usual practice is to fire the charge of cordite by means of a small quantity of fine powder, which is ignited either by a percussion cap, or by a metallic wire which is brought to incandescence by an electric current. Some records were taken in this way, but it was soon found that alterations in the amount and disposition of this firing charge, though leaving the actual maximum pressure almost unaffected, caused some variation in the shape of pressure curve (see fig. 9). When a relatively small quantity of the igniting charge is used in an

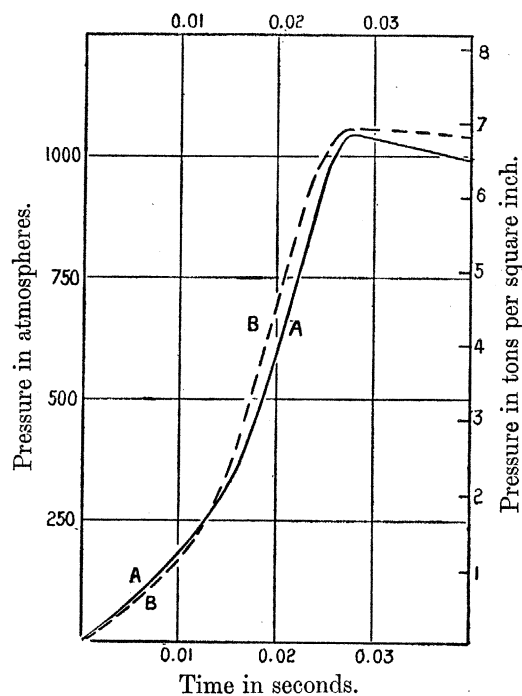

Fig. 9. Comparison of the effect of ignition by oxyhydrogen and gunpowder. Cordite of 0·175 inch diameter in a cylindrical enclosure; charge uniformly distributed; gravimetric density 0·1; A, fired with oxyhydrogen gas; B, fired with fine-grained powder.

enclosure of considerable length, only the part of the cordite in immediate proximity seems at first to take fire, and the flame is then propagated from layer to layer of the explosive. When the firing charge is larger, or the dimensions of the enclosure

smaller, or, thirdly, when very fine cord is used, a more satisfactory ignition is obtained. This point in itself would be well worth more careful investigation, but as the present research refers principally to the properties inherent to cordite itself, it was desirable to be independent of such disturbing factors. The ideal conditions would be realised if a method could be found of igniting every particle of the explosive at the same instant over its entire surface. These conditions are approached by the process used.

After the required quantity of cordite had been filled in and the explosion chamber closed, the air therein contained was displaced by a mixture of oxygen and hydrogen at, or near, atmospheric pressure, and this was fired off in the usual way by an electric current. The velocity of the explosion of this mixture is such that the effect of the gaseous combustion is practically over before the pressure of the burning cordite begins to make itself felt, and each cord, being entirely surrounded by the flaming gases, cannot fail to ignite over its entire surface. On the records the impact of this preliminary explosion is marked by a slight tremor occurring just before the actual rise of pressure occurs. The pressure due to the gaseous explosion is about 10 atmospheres which, when compared with the 1000 or 2000 atmospheres resulting from the explosion of the cordite, does not form a serious correction.

General Shape of the Curves.

All the records exhibit certain general characteristics. The typical curve of rise of pressure is illustrated in fig. 10. It consists of three parts: (*a*) beginning nearly

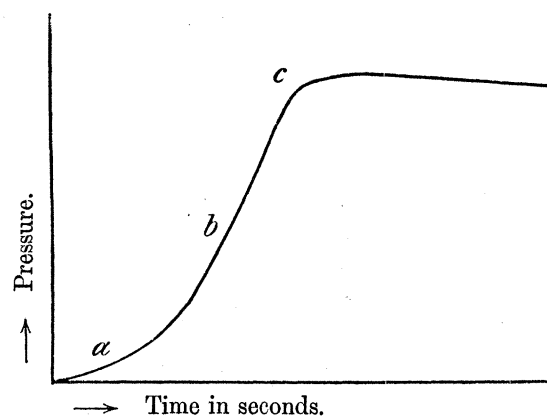

Fig. 10. Typical time pressure curve resulting from the explosion of cordite in closed vessel.

asymptotical to the time axis and, gradually rising more rapidly, corresponds to the first stage of the combustion; (*b*) referring to the full blast of the explosion, shows a much faster and almost constant rate of rise; while at (*c*) the rapid decrease in the surface of the explosive can no longer be counterbalanced by the accelerating effect of the higher pressure. At *c*, therefore, the curve turns round sharply and merges into the cooling curve. So much for the general shape of the records. As we shall see

below, a more detailed study shows that, while conserving the same configuration, the actual curve may, according to circumstances, either be smooth (see Plate 21, figs. 1 and 2), or made up of continuous vibrations (see Plate 21, fig. 3), or, thirdly, composed of a series of small but sharp steps corresponding with the successive impacts of the explosion wave (see Plate 21, fig. 4).

Effect of the Diameter of Cordite.

The velocity of the explosion depends primordially on the diameter of the cordite, but is modified to some extent by the distribution, the method of firing, and more especially by the gravimetric density. Fig. 11 shows the rise of pressure for three

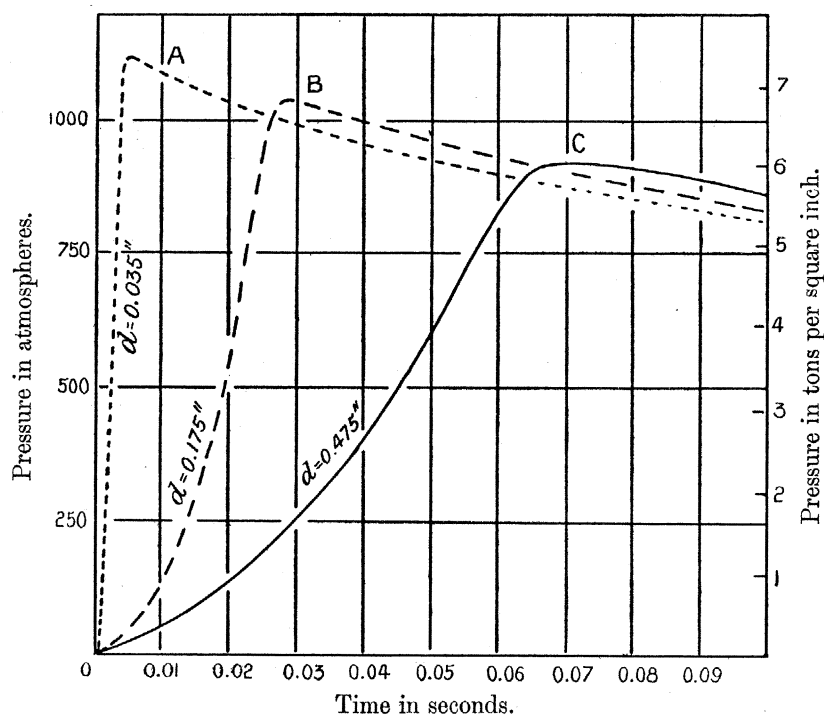

Fig. 11. Showing variation of rate of explosion with size of cordite used.

Gravimetric density 0.1; charge uniformly distributed; cylindrical enclosure used; A, diameter of cord 0.035 inch; B, diameter of cord 0.175 inch; C, diameter of cord 0.475 inch.

different diameters of cord (0.475 inch, 0.175 inch, 0.035 inch); the gravimetric density is in every case 0.10. The largest size is used for heavy ordnance, the smallest size for the army rifle. The three tests were made under the same conditions and in the same enclosure.

Fig. 12 relates to a similar experiment carried out at a higher pressure. Lastly, in fig. 13, the time required for the complete combustion of cordite of various diameters is plotted for three distinct gravimetric densities.

The relation between the time occupied by the explosion and the diameter of the cordite, as shown in this figure, is practically a linear one, the lines converging

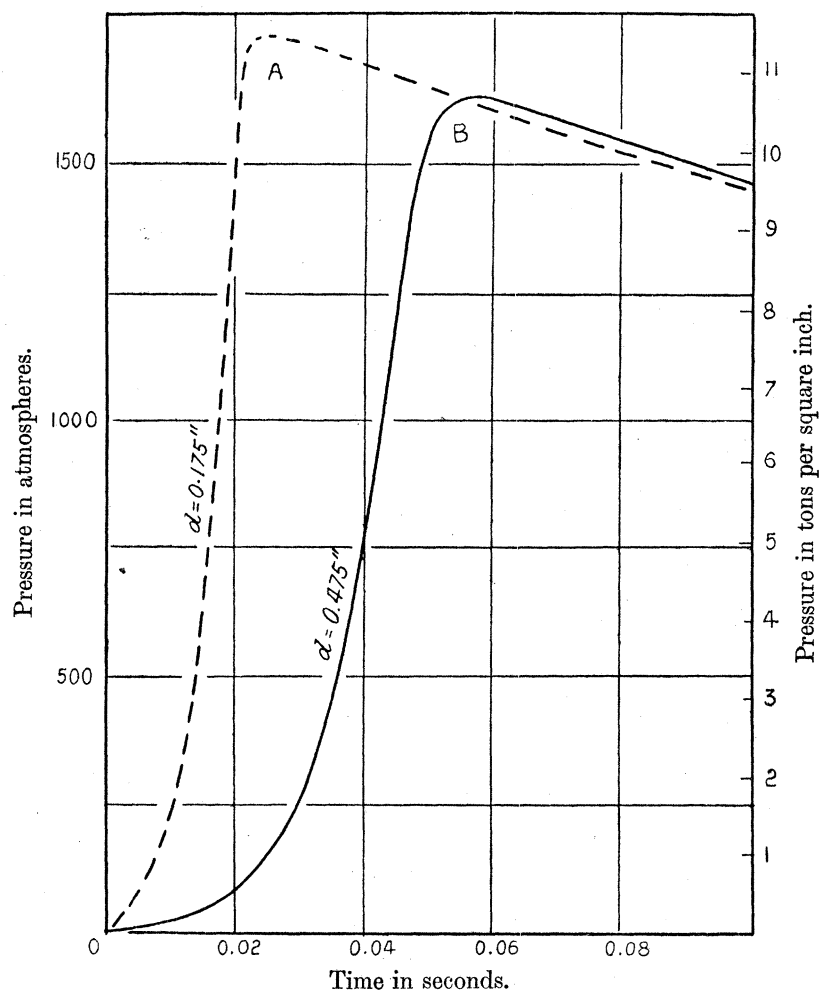

Fig. 12. Showing variation of rate of explosion with size of cordite.

Gravimetric density 0.15; charge uniformly distributed; cylindrical enclosure used; A, diameter of cord 0.175; B, diameter of cord 0.475.

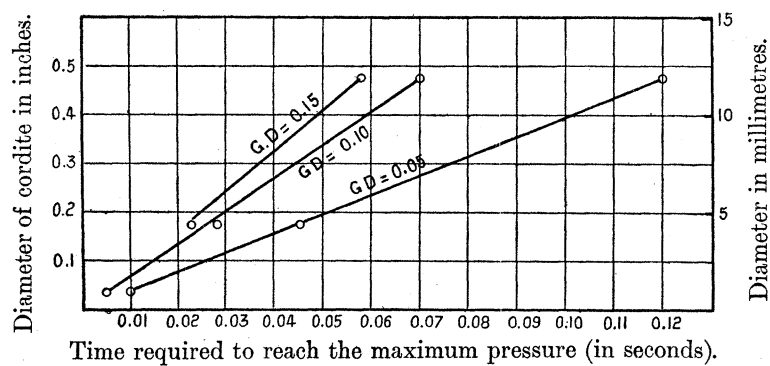

Fig. 13. Effect of the gravimetric density and of the diameter of the explosive on the time required to reach the maximum pressure.

towards the zero of time and diameter. We may, therefore, conclude that the combustion of finely divided cordite is nearly instantaneous. Under such conditions the result of an explosion would be very destructive, and it is possible that some abnormal effects which have on certain occasions been observed may be due to the pulverisation of the explosive at any early stage of the combustion.

However rapid an explosion may be, it remains, in principle, very distinct from a detonation. In an explosion the combustion is propagated from layer to layer without discontinuity. In a detonation the chemical reaction is practically instantaneous and simultaneous throughout the entire mass. The determining cause is, in this case, a compression wave of sufficient intensity to raise the material to its temperature of ignition.

Let us take for the sake of illustration a numerical example, although the values employed can only be rough estimations, and suppose a sphere of cordite 1 centim. in diameter under a gravimetric density of 0.1. If this were ignited in the ordinary way, the combustion would travel towards the centre of the sphere at an average rate of 8 centims. per second and the maximum pressure would therefore be reached in 0.063 second. If, on the other hand, the material were to detonate, the detonation wave would travel through the mass at a speed of something like 800,000 centims. per second,* and the total time occupied would be one hundred thousand times less.

In an explosion we have usually to deal with pressures which may be considered as statical as far as their action is concerned; in a detonation with a dynamical pressure or impact. The impact of the products of combustion travelling with enormous velocity may correspond in effect to an instantaneous pressure five or ten times greater than the normal pressure calculated from the composition of the explosive and its heat of reaction.

A typical case of this kind occurred when working with a compressed mixture of coal gas and oxygen. The total pressure of the explosion should have been some 4 or 5 tons per square inch. The mixture, however, detonated, and the solid steel piston of the recorder, though encased in a steel cylinder over 2 inches thick, was expanded outwards like the head of a rivet.† It is not easy to estimate exactly the statical pressure required to produce a corresponding effect, but it cannot be less than 25 tons per square inch.

To return now to the work on cordite, the results obtained with one of the smallest diameters in use are shown in fig. 14. It will be seen that, though the time occupied by the combustion is small, amounting to less than 0.008 of a second, the shape of the

* ABLE found that the rate of detonation of a train of dynamite or guncotton was about 608,000 centims. per second. See also SÉBERT, BERTHELOT and METTEGANG. The latter ('Ber. 5. Int. Kong. Ang. Chem., Berlin, 1903,' vol. II., p. 322) gives 700,000 centims. per second as the detonation rate of dynamite.

† A similar effect is recorded by NOBLE ('Proc. R. I.,' 1900), as having been produced on the copper of a crusher gage by a charge of lyddite.

curve is perfectly normal, showing clearly the three distinct stages of combustion referred to on p. 373.

The law of combustion by parallel surfaces as expounded by VIEILLE* applies well to the case of cordite.†

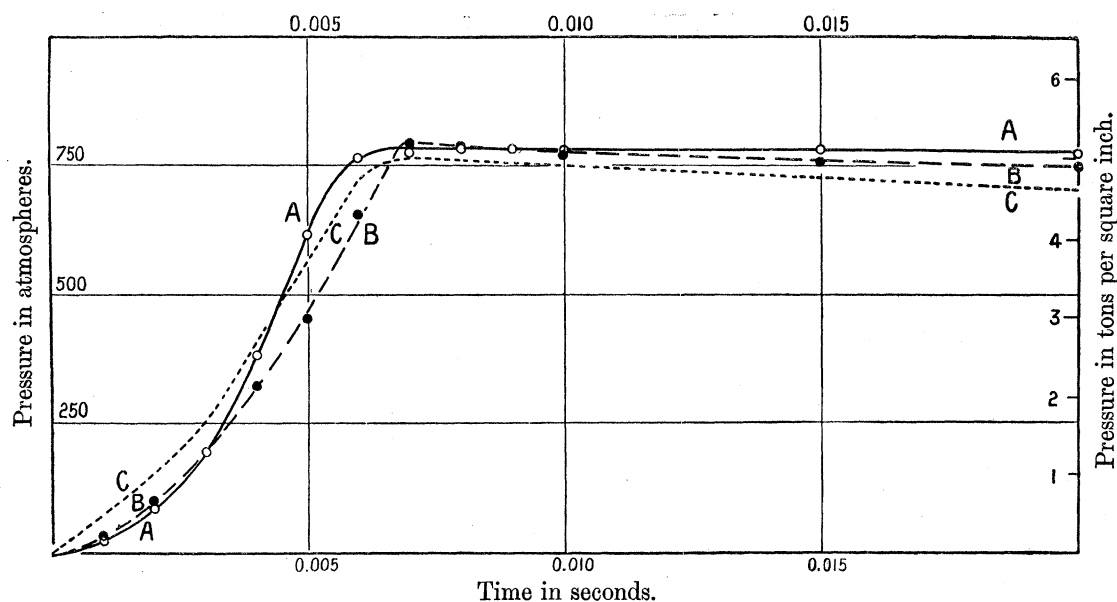

Fig. 14. Showing the rate of rise of pressure for cordite of the smallest diameter.
Diameter 0·035 inch (0·89 millim.).

A, spherical enclosure; charge uniformly distributed; gravimetric density 0·074. B, cylindrical enclosure; charge uniformly distributed; gravimetric density 0·075. C, cylindrical enclosure; charge concentrated in one quarter of cylinder, nearest the recorder; gravimetric density 0·075.

The speed at which the flame travels inwards towards the centre of each cord is uniform and relatively slow. When unconfined, cordite burns at a rate of about 0·5 centim. per second. In a closed vessel the *average* speed increases to 5 centims. per second for an explosion developing 500 atmospheres, 8 centims. for a maximum of 1000 atmospheres, and 11 centims. per second for 2000 atmospheres.‡

The shape of the curve representing the rise of pressure depends essentially on two

* 'Comptes Rendus,' vol. 118, pp. 346, 458, 912; 1894.

† The peculiarly regular combustion of cordite was first noticed by NOBLE, who in 1892 ('Proc. Roy. Soc.,' vol. 52, p. 129) remarks that the pieces of cordite blown from the muzzle of the experimental gun he was using were so uniformly decreased in diameter that they might readily have been mistaken for newly manufactured cordite of smaller diameter.

‡ The time required for the full pressure to develop is, therefore, proportional to the diameter of the cord. The formula $L = r/c$ (where L is the time in seconds and r the radius in centimetres) gives a fair approximation, though, as we shall see, the actual time varies somewhat, according to the conditions of the experiment. The constant c is characteristic of the explosive and, of course, equal to the above rates of combustion.

factors: (1) on the surface of the explosive exposed to combustion and hence on the radius of the cords at each instant during the reaction; (2) on the radial speed at which the zone of combustion is travelling towards the centre of each cord. This speed may be taken as proportional to the pressure. The formula $S = \alpha p$ (where S is the speed in centimetres per second, p the instantaneous pressure in tons per square inch, and α an empirical constant equal to about 3.5) may be of use where it is not possible to make a direct experimental determination.

The maximum pressure (P) developed by a given charge is usually well known, and by aid of the above formula the curve of rise of pressure can therefore be obtained. The radius of the cordite for successive intervals of pressure ($p = 0.1 P$, $p = 0.2 P$, &c.) is first computed, and the time required to burn through the corresponding distance at the average pressure ($p = 0.5 P$, $p = 0.15 P$, &c.) is then determined. In calculating the radius, the volume of the unburnt explosive must, of course, be taken into account, and this renders the work somewhat tedious.

The formula does not take into account the fact that under experimental conditions some time elapses while the flame is spreading before the normal rate of combustion is set up. The zero of the calculated curve is, therefore, shifted somewhat to the right, and a sharper slope given to the initial stage (α , fig. 10).

It may with some truth be argued that the error occurring at a very low pressure would not affect the results as applied to ballistics, the calculation and experimental curves being in agreement by the time the motion of the shot commences. It is hoped, however, that the day is not far distant when we shall be able to obtain an indicator card from a gun with the same ease as we now indicate other heat engines; approximate calculations such as the above will then cease to be of practical value.

We have explained above the system used for firing the charge. When the key is pressed, the atmosphere of oxyhydrogen, with which the enclosure has been filled, explodes and the cordite is surrounded by a sheet of flame. The time at which this takes place is recorded by a slight tremor of the gauge. The charge does not ignite at once,* for though the explosive is surrounded by an intensely hot flame, a quite appreciable time is required for its surface to rise to the temperature of ignition.†

The ignition begins at the ends of each stick or at other parts, where, for instance owing to a blister, the conductivity has been reduced. The last parts to be attacked are those which were in contact with the walls of the enclosure or with some other portion of the charge. These circumstances, together with a slow rate of combustion which is characteristic of cordite under very low pressures, account for the gentle slope of the first part of each curve.

* In the appended tables and curves, time is counted from the instant the cordite ignites, as marked by the first permanent rise of pressure.

† A stick of cordite may under ordinary conditions be passed comparatively slowly through the flame of a Bunsen burner without igniting. If, however, its surface has previously been scratched or scored, the smaller particles will ignite at once and set fire to the mass.

When fully ignited, each particle is freely suspended in space, being kept from direct contact with other bodies by the rush of flame issuing from its surface. It is to these conditions that the law of combustion by parallel layers accurately applies.

While the combustion is taking place, heat is being continually transmitted to the walls of the enclosure, and the maximum pressure attained will therefore be less for a slow explosion than for a fast one; the actual effect may be seen by reference to figs. 11, 12 and 15.

The heat loss accounts also, as stated above, for the manner in which the curves of rise and fall of pressure merge together. By the time the maximum pressure is nearly reached the diameter of each particle of explosive is greatly reduced. The weight of substance consumed per unit time begins therefore to decrease, although the flame is actually advancing towards the axis of each cord at an ever increasing speed. Finally, the combustion just counterbalances the total thermal loss, and the curve of pressure remains for an instant practically constant at its maximum value. This will be seen clearly in figs. 1 and 2 on Plate 21.

Effect of the Enclosure.

We have just referred to the thermal loss due to the cold walls of the explosion chamber. The total loss, *cæteris paribus*, is proportional to the time.

When the diameter of the cordite, and consequently the time occupied by the combustion, is very small, the theoretical value of the maximum pressure is closely approached, and the shape and size of the enclosure have but little effect (compare A and B, fig. 14). These factors become, however, of considerable importance in determining the maximum pressure developed by the slower burning cordite (see fig. 15).

The shape of the cooling curve depends, on the other hand, essentially on the dimensions of the enclosure. In fig. 16 the facts are clearly illustrated by the results of comparative experiments carried out respectively in a sphere and in the cylinder.

It is proposed to reserve the general discussion of the questions of dissociation and rate of cooling for the third part of the present research; we shall then be dealing with gaseous mixtures of simple composition which will serve as a natural introduction to the consideration of more complicated questions. A few words are, however, necessary with regard to the somewhat unusual conditions under which the cooling of the products of combustion of a solid explosive takes place.

Under ordinary circumstances the convection and conductivity of the gas itself are the ruling factors which determine the rate of cooling.

The thermal capacity of the gaseous mixture and the rate at which heat can be transmitted through it are low compared with the corresponding properties of the enclosure. These facts hold true whether the latter is water-cooled or not.

In such cases neither the inner surface of the enclosure nor the layer of gas in

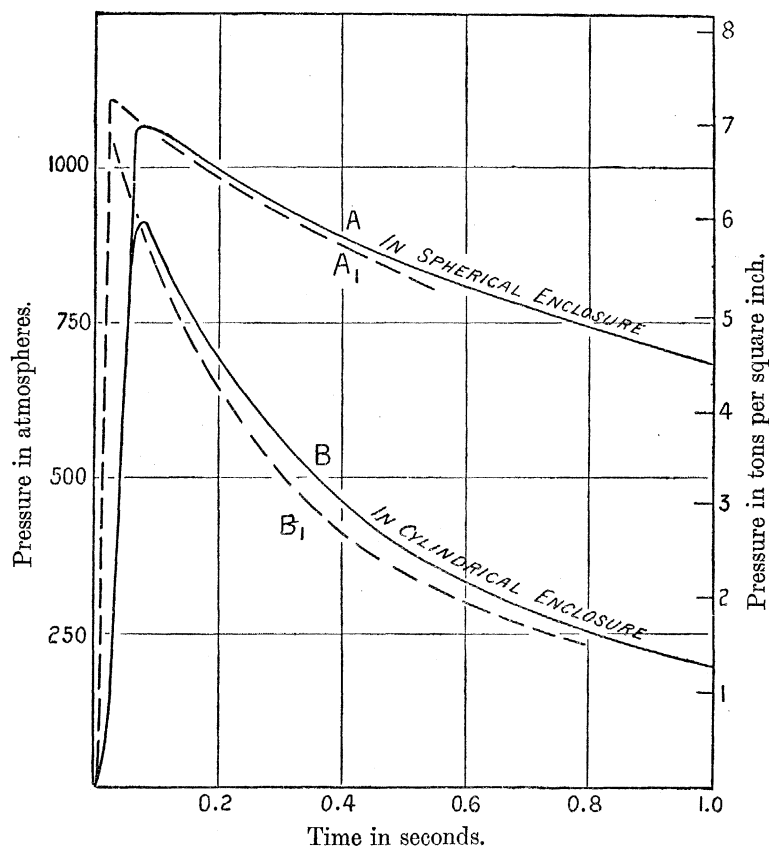

Fig. 15. Showing the effect of the shape of the enclosure on the maximum pressure developed by cordite of large diameter.

Gravimetric density 0.1; charge uniformly distributed; A and A₁, in spherical enclosure; B and B₁, in cylindrical enclosure; A and B, diameter of cord 0.475 inch (12.07 millims.); A₁ and B₁, diameter of cord 0.175 inch (4.44 millims.).

contact with it rise much above atmospheric temperature, and the rate at which heat is dissipated depends on the temperature gradient which is set up in the gaseous mass.

In previous papers* I have pointed out how the rate of transmission of heat in a gas varies with the pressure. In the case of air, for instance, the law

$$E \times 10^6 = 403p^{0.56} + 1.63p^{0.21} \vartheta$$

was verified up to 1000° C. and 170 atmospheres.† At this pressure already air transmits heat at the same rate as a substance having twenty times the conductivity of air at atmospheric pressure.

* 'Phil. Trans.,' A, vol. 191, pp. 501, 524, 1898; and vol. 197, pp. 229-254, 1901.

† E is the heat abstracted from each square centimetre of surface of the hot body measured in therms per second per degree temperature interval. ϑ is the temperature of the hot surface measured in degrees Centigrade, and p the pressure of the surrounding gas in atmospheres.

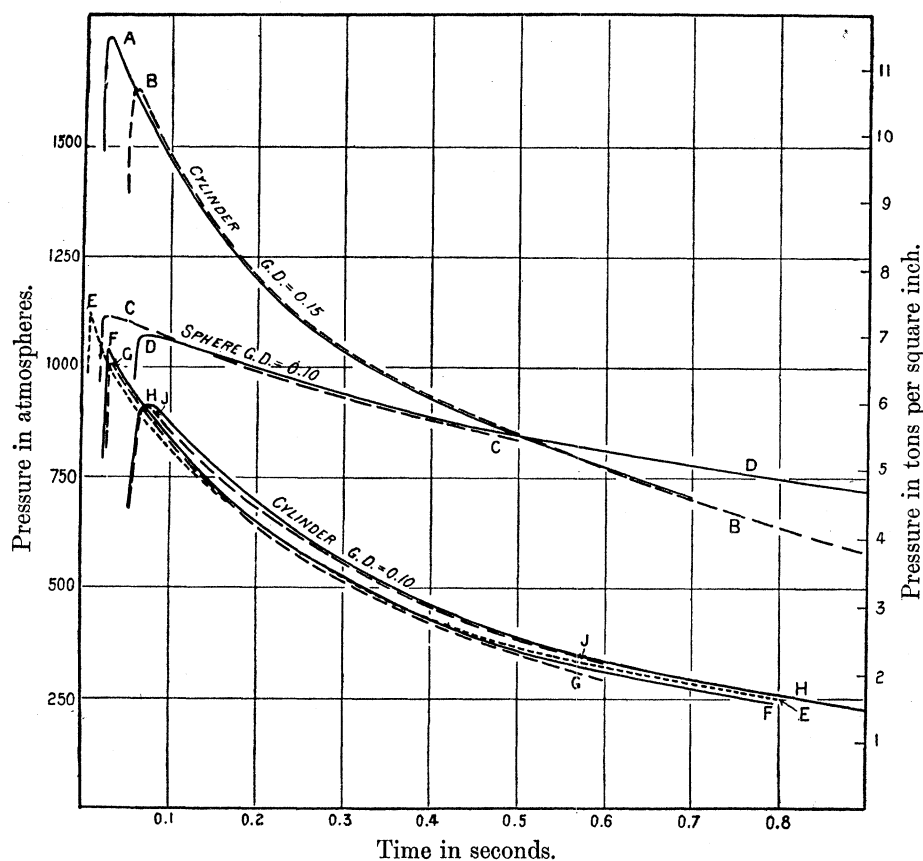

Fig. 16. Effect of the dimensions of the enclosure on the rate of cooling of the products of combustion.

A,	cylindrical explosion vessel ;	gravimetric density 0.15 ;	diameter 0.175 ;	uniformly distributed.
B,	" " ;	" " 0.15 ;	" 0.475 ;	" "
C,	spherical " " ;	" " 0.1 ;	" 0.175 ;	" "
D,	" " ;	" " 0.1 ;	" 0.475 ;	" "
E,	cylindrical " " ;	" " 0.1 ;	" 0.035 ;	" "
F,	" " ;	" " 0.1 ;	" 0.175 ;	" "
G,	" " ;	" " 0.1 ;	" 0.175 ;	not uniformly distributed.
H,	" " ;	" " 0.1 ;	" 0.475 ;	uniformly distributed.
J,	" " ;	" " 0.1 ;	" 0.475 ;	not uniformly distributed.

When considering the products of an explosion, it must be remembered that the effective conductivity of the gas is further increased by its state of rapid motion. It is also augmented by the large proportion of hydrogen and water vapour contained therein.

As a result the temperature of the walls of the enclosure rises rapidly as the cooling of the gas proceeds, and before long the rate of cooling will depend essentially on the conductivity of the walls of the enclosure and not on the properties of the gas. The heat abstracted per unit time will then be simply proportional to the temperature.

If the logarithmic decrement of the latter part of the curve is measured, it will be found that the theory is confirmed in this respect by the results of the experiments.

The quantity of heat which is transmitted to the walls of the enclosure during the brief period occupied by the cooling of the gas is much greater than would occur in cases met with in ordinary engineering practice. With a gravimetric density of 0·1 the amount of heat to be absorbed per unit surface of our cylindrical enclosure is some hundred times as large as that which would be absorbed by the cylinder of an ordinary gas engine.

In the case of artillery of large calibre the inner surface of the steel probably attains a temperature close to its melting-point and the correspondingly plastic material yields easily under the combined friction and chemical action of any escaping gas. In the case of small arms, the temperature being limited by the relatively small volume and therefore small thermal capacity of the gaseous mass, practically no erosion takes place.

To return now to the experimental work. In the following table the time required for the pressure to fall to three quarters, one half, one quarter of its maximum value is given for a number of distinct experiments, whereas the cooling curves for three different diameters of cordite at gravimetric densities of 0·1 and 0·15 will be found plotted in fig. 16. It is noticeable that after the first tenth of a second the curves taken under similar conditions, but for various sizes of explosive, lie closely together, showing that the diameter has no material effect on the subsequent rate of cooling.

When we refer, however, to the table, we see that the times required to reach a given fraction of the maximum are different for different diameters.

This apparent discrepancy is explained by the fact that the total quantity of heat absorbed is primordially a function of time. When the combustion is very rapid, the maximum pressure is reached while the walls of the enclosure are still cold and the percentage fall of pressure per unit time is high. With a slow-burning cordite the surface of the enclosure becomes considerably heated during the combustion of the explosive, and after the maximum the percentage fall of pressure is correspondingly lower. Briefly stated, at any fixed interval of time after ignition the total heat absorbed by the enclosure, and, therefore, the temperature of its inner surface, will be nearly the same for all diameters of the explosive. In consequence, the rate of cooling as measured by the rate of change of pressure at any stated time is unaffected by the speed of combustion.

The rate of cooling for a given volume of the enclosure does not vary, as is usually assumed, in proportion to the surface, but nearly as the square of the surface.

It will be noticed that the cooling in the cylinder is about four times as rapid as in the sphere, whereas the ratio of the two surfaces is as 2·17 to 1.

In such massive enclosures the heat generated by the explosion is at first entirely absorbed by the inner layers of the steel walls. It does not travel to the outside until some time after the explosion is over. A decrease in the surface has, therefore, a double effect. The heat to be absorbed per unit area and the average thickness of metal through which this heat must be transmitted are both increased.

Rate of Cooling of Products of Combustion.

Enclosure	Spherical.		Cylindrical.															
	Diameter of cordite	0.175"	0.475"	0.175"	0.175"	0.475"	0.175"	0.475"	0.035"	0.035"	0.035"	0.035"	0.075"	0.075"	0.075"	0.075"	0.175"	0.175"
Gravimetric density	0.05	0.10	0.10	0.10	0.15	0.10	0.15	0.10	0.10	0.10	0.10	0.15	0.10	0.10	0.10	0.10	0.10	0.10
Distribution	Uniform.		Uniform.		Uniform (gunpowder ignition).		Uniform.		Uniform.		Uniform.		Uniform.		Non-uniform.		Non-uniform.	
Time, in seconds, required for the pressure to fall to three quarters of the maximum value	0.52	0.54	0.13	0.09	0.13	0.08	0.13	0.13	0.07	0.05	0.07	0.13	0.07	0.05	0.12	0.10	0.10	0.10
Time, in seconds, required for the pressure to fall to one half of the maximum value	—	—	0.34	0.27	0.35	0.26	0.48	0.44	0.18	0.17	0.18	0.44	0.18	0.17	0.33	0.29	0.28	0.28
Time, in seconds, required for the pressure to fall to one quarter of the maximum value	—	—	0.80	0.69	0.72	0.69	—	—	0.45	0.45	0.45	—	0.45	0.45	—	0.77	—	—

Relation of Pressure to Gravimetric Density.

The present work was not taken up with a view to specially investigating the above subject, which has already been fully treated by NOBLE. It is, however, of interest to compare the results with the much more complete set published by this investigator.

To minimise the effect of the rapid rate of cooling, which, as we have just seen, is inherent to small enclosures, we must select for comparison the values obtained when using cordite of relatively small diameter. The pressures obtained with cordite of 0·175 inch and 0·035 inch diameter are shown in fig. 17, marked in on the curve representing NOBLE's results, and are, as will be seen, in close agreement with it.

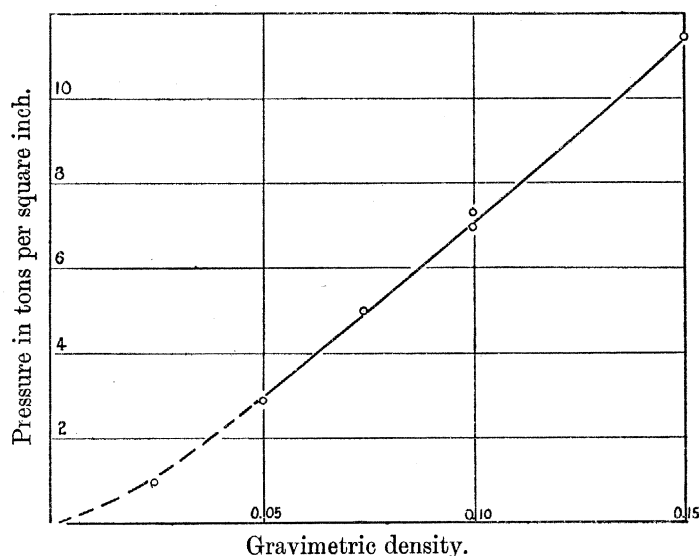

Fig. 17. Variation of maximum pressure with the gravimetric density of the charge.

The curve is traced out from the values given by Sir ANDREW NOBLE; the points marked on it refer to the results incidentally obtained in the course of the present work.

Though the pressure and temperature are exceptionally high, there is no reason for supposing that the products of combustion depart considerably from the law which governs the pressure of gases at ordinary temperatures.

This law may be written

$$(p + a)(v - b) = RT.$$

In the present case, where the temperature is very high and constant, we may put $RT = c$, and for a first approximation neglect cohesion of the gas.

The formula then takes the simple form

$$p(v - b) = c.$$

The volume to which the gas will be reduced under infinite pressure may be taken as closely approaching the inverse of the density of the solid explosive. Therefore

$$b = \frac{1}{1.56} = 0.641,$$

whereas v is the inverse of the gravimetric density ρ .

Thus

$$c = \frac{p}{\rho} - 0.641p.$$

To minimise the error due to cooling we will take the value of p obtained for the smallest cordite in the spherical enclosure. At a gravimetric density of 0.0744 this is 5.137 tons per square inch (see Table VI.), and therefore

$$c = \frac{5.137}{0.0744} - 0.641 \times 5.137 = 65.75.$$

The pressure developed by the explosive is

$$p = \frac{c\rho}{1-b\rho} = \frac{65.75\rho}{1-0.641\rho}.$$

The results calculated from this formula are compared in the following table with NOBLE'S values and with those obtained during the course of the present work* :—

Gravimetric density.	Pressure calculated.	Pressure determined experimentally by NOBLE.	Pressure determined experimentally by PETAVEL.
0.05	3.40	3.00	2.87
0.10	7.03	7.10	7.01
0.15	10.91	11.36	11.48
0.20	15.08	16.00	—
0.30	24.42	26.00	—
0.40	35.37	36.53	—
0.50	48.38	48.66	—
0.60	64.10	63.33	—

In the above table the pressures are expressed in tons per square inch.

The experimental results are influenced by many factors, such as the size of the enclosure, the dimensions of the explosive, and the oscillations of pressure, which are doubtless occasionally set up. On the other hand, the formula we have used does not

* When the pressure is measured in kilogrammes per square centimetre the constant c becomes 10355, whereas $c = 10021$ gives the pressure in atmospheres, the constant b in either case remaining unaltered. A formula similar to the above was used by NOBLE and ABEL in connection with their researches on fired gunpowder. They assumed that the gases strictly followed BOYLE'S law, but introduced a factor $(1 - \alpha\rho)$ to allow for the space occupied by the solid residues left after the explosion.

take into account the cohesion of the gas, or allow for the possible variation of the value b with temperature and density.

Taking these circumstances into account, the agreement between the theoretical and experimental values may be considered satisfactory.

Distribution of the Explosive.

In a long narrow vessel a certain amount of vibration almost invariably occurs during the combustion of the explosives. If the explosive is concentrated in one part only of the enclosure, the effect is increased and the pressure rises by sharp steps, as shown in fig. 18. With some powders the sudden increments of pressure become

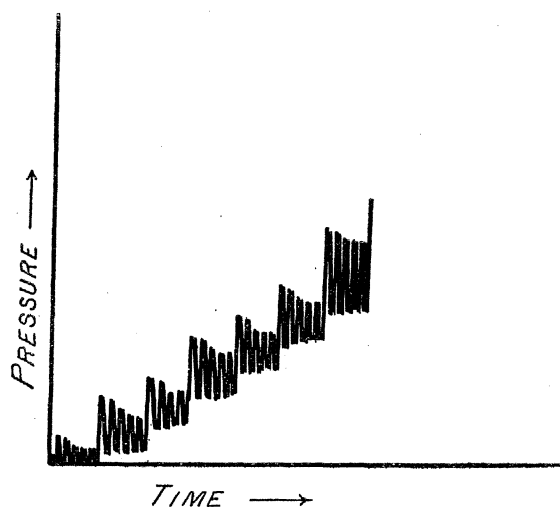

Fig. 18. Diagram showing the type of vibration set up at the commencement of an explosion when the charge placed in a long enclosure is not uniformly distributed. The successive sharp increments of pressure correspond with successive impacts of the wave.

dangerously large and an abnormally high maximum is reached in one or two steps. This phenomenon seems to be the transition between an explosion and a detonation.

That it is difficult, in fact almost impossible, to detonate cordite has long been recognised as one of its principal advantages. Nevertheless, signs of abnormal explosion were visible whenever the charge was crowded together in one part of the enclosure. A fairly typical case is shown in fig. 4, Plate 21, a similar effect being recorded in many other cases, notably F 68, F 69, and F 70 (Tables XI., XII., XIII.).

The experiments in this direction had to be confined to pressures of about 1000 atmospheres. From these tests it seems probable that by working under similar conditions, but with a higher gravimetric density, cordite would give results not unlike those obtained by VIEILLE* in the case of "B.F." and other powders.

* See "Étude des Pressions Ondulatoires," 'Annales des Poudres et Salpêtres,' vol. III., pp. 177-236. VIEILLE, in the course of this work, obtained instantaneous pressures amounting to three times the normal value. Using a method of calculation similar to that given below, he showed that the speed of propagation of the smaller disturbance is in fair agreement with the speed of sound in the same medium.

Unfortunately, for this very reason, the experiments could not be carried out in a laboratory.

The sharp steps which go to make up these records may be accounted for in the following manner: When the explosive, which is packed closely at one end of the chamber, bursts into flame, a pressure wave is sent out which travels to the end of the cylinder and is then reflected back. When this wave, on its return journey, reaches the explosive, the combustion, which in the meantime had been proceeding uniformly, is accelerated in proportion to the increased pressure. The case is one of mutual reaction between the two phenomena. Any irregularity in the combustion tends to start a pressure wave which in turn enhances this irregularity. The process is cumulative in its effects, and with the high gravimetric densities used in ballistic work it may, and doubtless occasionally does, cause disastrous results.*

Incidentally the present work confirms VIELLE'S† views as to the discontinuity of pressure set up by wave actions, the successive steps of the curve rising abruptly, if not instantaneously.

The velocity of propagation of the wave is measured directly by the time elapsing between the successive sharp increments of pressure which are recorded.

When a wave is set up at the commencement of the explosion, the impacts on the recording gauge succeed each other at intervals of 0·00125 or 0·00121 second when the charge in the cylinder is at gravimetric densities of 0·10 or 0·15 respectively. The path traversed, *i.e.*, the double length of the enclosure, is 139·3 centims. and the corresponding velocities 1114, 1150 metres per second.‡

Occasionally, when cordite of the smallest diameter is used, the wave motion is still sharply defined at the maximum pressure. The time interval is then 0·00110 second for a gravimetric density of 0·1 and the speed 1266 metres per second.

From the general formula for the velocity of sound we can calculate the theoretical speed under these circumstances,

$$V = \sqrt{\frac{\gamma E}{\rho}}.$$

These factors, with the exception of γ , are well known.

When the combustion is complete, the density, ρ , of the resulting gases is equal to the gravimetric density of the charge.

The elasticity, E , is measured by the rate of change of pressure with density.

$$E = \rho \frac{dp}{d\rho}.$$

* See CORNISH, 'Proc. Inst. Civ. Eng.,' vol. 144, p. 241, 1901.

† 'Mémorial des Poudres et Salpêtres,' vol. 10, pp. 177–260, 1899–1900.

‡ Theoretically the speed should be the same in either case; the thermal loss, which is relatively less at higher gravimetric densities, probably accounts for the difference.

It can, therefore, be obtained by differentiating the expression

$$p = \frac{\rho c}{1 - \rho b},$$

which was given on p. 385.

Carrying out this operation we find

$$E = p \left(1 + \frac{pb}{c} \right).$$

The value of the ratio of the specific heats, γ , is somewhat uncertain. For the mixture of gases resulting from the explosion, γ may be taken as 1·35 or 1·21, according as the specific heats are considered constant or variable with temperature.

The following table gives the velocity of sound, calculated according to each of the above hypotheses :—

VELOCITY of Sound in the Gases Produced by the Combustion of Cordite at the Maximum Pressure of the Explosion, measured in Metres per Second.

Gravimetric density.	Velocity for = 1·35.	Velocity for = 1·21.
0·1	1251	1185
0·2	1343	1272
0·3	1450	1373
0·4	1575	1491
0·5	1723	1632
0·6	1903	1801

The limiting value for low densities, which should correspond with the speed of the wave at the commencement of the explosion, works out at 1170 ($\gamma = 1·35$) or 1108 ($\gamma = 1·21$).

Although, strictly speaking, the above theory applies only to very small disturbances, the calculated velocities are in fair agreement with the measurements given on p. 387.

The oscillations referred to in the preceding paragraph are superimposed on the curve of pressure without directly altering its general shape. Within the limits of the present experiments the wave action, consequent on the uneven distribution of the charge, by increasing the thermal loss slightly lowers the maximum pressure. The rate of combustion is, also, somewhat altered; usually it is accelerated.

These effects will be best understood by reference to figs. 14, 19, and 20, in which the mean values of the pressure are plotted in terms of the time.

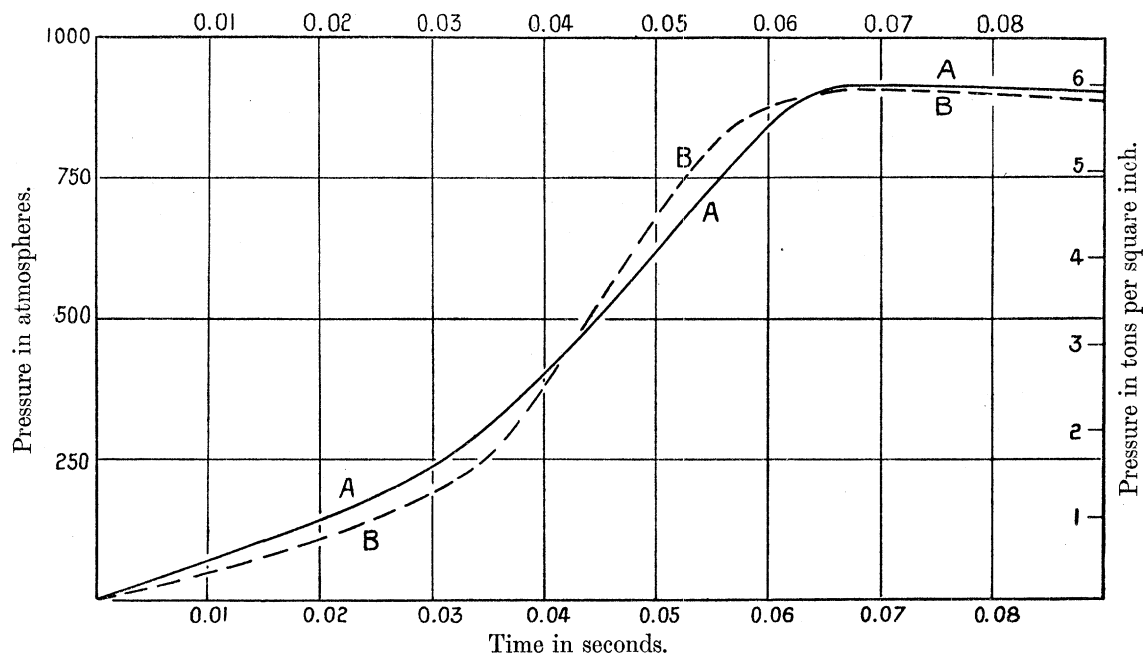

Fig. 19. Variation of the rate of combustion and of the maximum pressure produced by a non-uniform distribution of the charge.

Cylindrical enclosure; gravimetric density 0.1; diameter of cord 0.475 inch (12.07 millims.). A, charge uniformly distributed; B, charge placed in one sixth of the cylinder near the recorder.

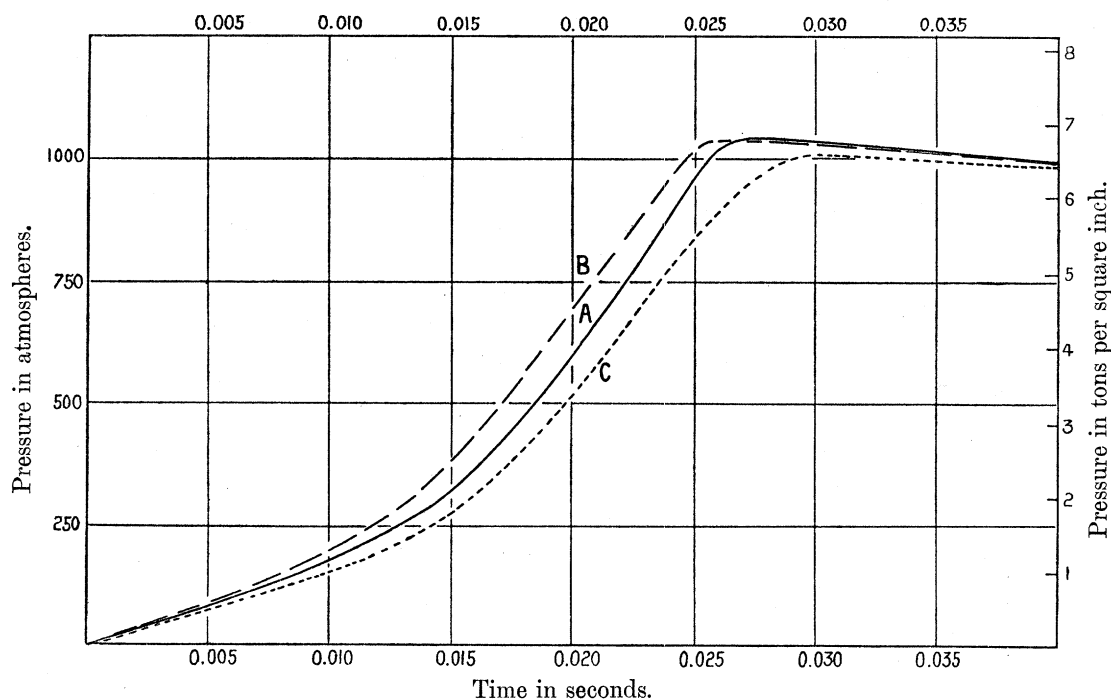

Fig. 20. Variation of the rate of combustion and of the maximum pressure produced by a non-uniform distribution of the charge.

Cylindrical enclosure; gravimetric density 0.1; diameter of cord 0.175 inch (4.44 millims.). A, charge uniformly distributed; B, charge placed in one half of the cylinder farthest from the recorder; C, charge placed in one sixth of the cylinder farthest from the recorder. This case is somewhat exceptional. The charge was so closely packed that it formed a nearly solid mass, which was probably scattered on ignition by the pressure of the gas produced behind it.

Generally speaking, the results obtained confirm the remarkable properties of cordite with regard to its high power and to the regularity of the effects produced. It would doubtless be very desirable to extend the research to higher pressures and carry out, on similar lines, a comparative study of other explosives. Treated, however, in this general way the subject is too vast to be dealt with single-handed, and the writer can but express a hope that others more competent and better equipped will be found willing to take up the work.

Before closing I desire to thank Professor ARTHUR SCHUSTER for placing at my disposal the ample resources of his laboratory.

The cost of the apparatus has to a large extent been defrayed by funds awarded by the Government Grant Committee of the Royal Society, while for the cordite I am indebted to the courtesy of the War Office authorities.

APPENDIX.

In the following tables numerical results obtained from the measurements of the principal photographic records will be found.

Where wave action is set up, the pressure given is the mean value of the instantaneous pressure at the time indicated.

TABLE I.—(Record No. F 55.)

Spherical explosion vessel ; charge uniformly distributed ; gravimetric density 0·0496 ; diameter of cord 0·475 inch (12·07 millims.).

Maximum pressure 404 atmospheres (2·65 tons per square inch) ; time required to reach the maximum pressure 0·120 second.

Time in seconds.	Pressure in atmospheres.	Time in seconds.	Pressure in atmospheres.
0·010	10	0·130	404
0·020	22	0·200	397
0·030	31		
0·040	43		
0·050	67		
0·060	98		
0·070	150		
0·080	215		
0·090	287		
0·100	363		
0·110	397		
0·120	404		

TABLE II.—(Record No. F 56.)

Spherical explosion vessel; charge uniformly distributed; gravimetric density 0·0496; diameter of cord 0·175 inch (4·44 millims.).

Maximum pressure 438 atmospheres (2·87 tons per square inch); time required to reach the maximum pressure 0·045 second.

Time in seconds.	Pressure in atmospheres.	Time in seconds.	Pressure in atmospheres.
0·005	24	0·100	438
0·010	48	0·200	421
0·015	86	0·300	390
0·020	131	0·400	364
0·025	187	0·500	339
0·030	271		
0·035	383		
0·040	433		
0·045	438		
0·050	438		

TABLE III.—(Record No. F 57.)

Spherical explosion vessel; charge uniformly distributed; gravimetric density 0·024; diameter of cord 0·035 inch (0·89 millim.).

Maximum pressure 144 atmospheres (0·95 ton per square inch); time required to reach the maximum pressure 0·014 second.

Time in seconds.	Pressure in atmospheres.	Time in seconds.	Pressure in atmospheres.
0·002	12	0·020	144
0·004	28	0·050	143
0·006	52	0·100	141
0·008	77		
0·010	103		
0·012	127		
0·014	144		

TABLE IV.—(Record No. F 59.)

Spherical explosion vessel; charge uniformly distributed; gravimetric density 0·099; diameter of cord 0·475 inch (12·07 millims.).

Maximum pressure 1069 atmospheres (7·01 tons per square inch); time required to reach the maximum pressure 0·065 second.

Time in seconds.	Pressure in atmospheres.	Time in seconds.	Pressure in atmospheres.
0·005	10	0·070	1069
0·010	34	0·100	1062
0·015	53	0·200	993
0·020	79	0·300	935
0·025	113	0·400	883
0·030	160	0·500	840
0·035	244	0·600	804
0·040	357	0·700	773
0·045	521	0·800	746
0·050	684	0·900	716
0·055	880	1·000	689
0·060	1024		
0·065	1069		

TABLE V.—(Record No. F 60.)

Spherical explosion vessel; charge uniformly distributed; gravimetric density 0·099; diameter of cord 0·175 inch (4·44 millims.).

Maximum pressure 1115 atmospheres (7·31 tons per square inch); time required to reach the maximum pressure 0·022 second.

Time in seconds.	Pressure in atmospheres.	Time in seconds.	Pressure in atmospheres.
0·002	29	0·024	1112
0·004	59	0·030	1109
0·006	103	0·100	1062
0·008	150	0·200	986
0·010	229	0·300	927
0·012	370	0·400	874
0·014	522	0·500	821
0·016	754		
0·018	971		
0·020	1089		
0·022	1115		

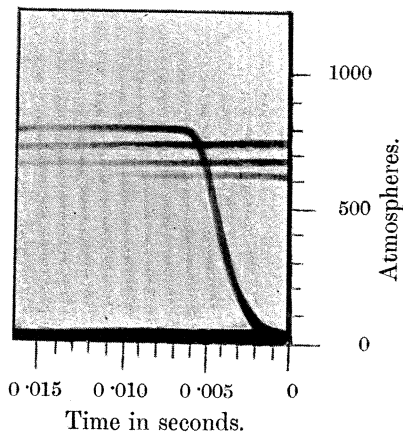

Fig. 1.

Cordite 0.035 inch diameter.
Gravimetric density = 0.0744.
Charge uniformly distributed in spherical enclosure.

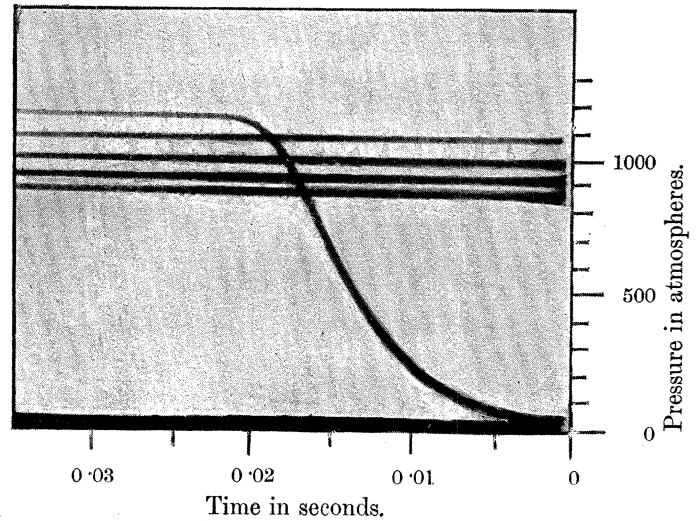

Fig. 2.

Cordite 0.175 inch diameter.
Gravimetric density = 0.099.
Charge uniformly distributed in spherical enclosure.

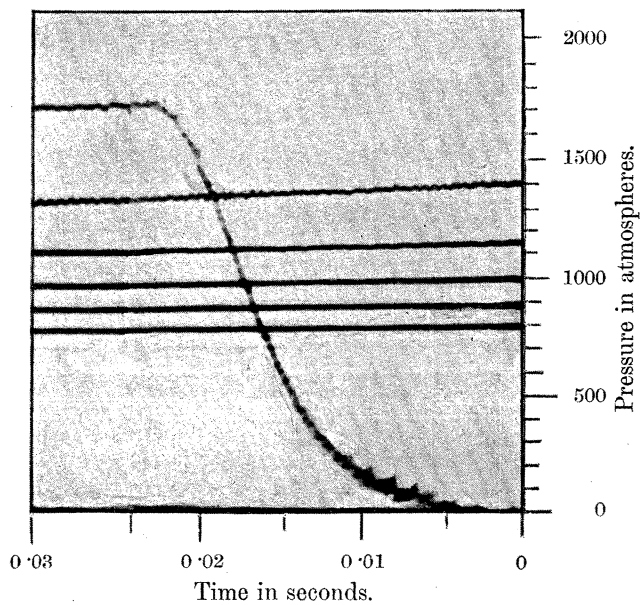

Fig. 3.

Cordite 0.175 inch diameter.
Gravimetric density = 0.15.
Charge uniformly distributed in cylindrical enclosure.

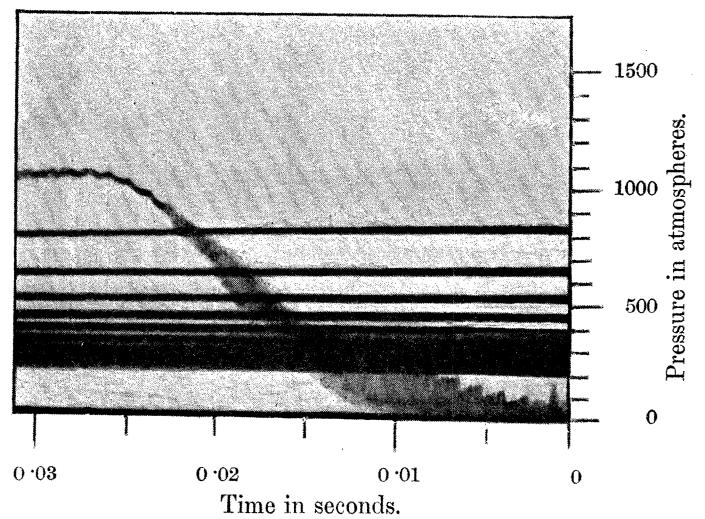

Fig. 4.

Cordite 0.175 inch diameter.
Gravimetric density = 0.10.
Charge concentration in one half of the cylindrical enclosure.

N.B.—The above figures are reproduced full size from the original negatives. The series of lines which cross the records in a direction nearly parallel to the axis of time correspond to successive portions of the cooling curve. They represent the pressure after 1, 2, 3, &c., complete revolutions of the chronograph drum. In most cases the light was cut off and the record stopped less than a second after the explosion, thus leaving the lower part of the diagram clear.

TABLE VI.—(Record No. F 61.)

Spherical explosion vessel; charge uniformly distributed; gravimetric density 0·0744; diameter of cord 0·035 inch (0·89 millim.).

Maximum pressure 783 atmospheres (5·137 tons per square inch); time required to reach the maximum pressure 0·008 second.

Time in seconds.	Pressure in atmospheres.	Time in seconds.	Pressure in atmospheres.
0·001	23	0·010	783
0·002	85	0·015	783
0·003	202	0·020	772
0·004	381	0·050	769
0·005	616	0·100	728
0·006	763	0·200	669
0·007	774	0·300	622
0·008	783	0·400	587

TABLE VII.—(Record No. F 63.)

Cylindrical explosion vessel; charge uniformly distributed; gravimetric density 0·1004; diameter of cord 0·475 inch (12·07 millims.); temperature 18·6° C.

Maximum pressure 916 atmospheres (6·01 tons per square inch); time required to reach the maximum pressure 0·070 second.

Time in seconds.	Pressure in atmospheres.	Time in seconds.	Pressure in atmospheres.
0·010	76	0·075	916
0·020	139	0·080	916
0·030	231	0·090	892
0·040	400	0·100	866
0·050	618	0·200	694
0·060	843	0·300	562
0·065	909	0·400	463
0·070	916	0·500	397
		0·600	331
		0·700	291
		0·800	255
		0·900	225
		1·000	198

TABLE VIII.—(Record No. F 65.)

Cylindrical explosion vessel; charge uniformly distributed; gravimetric density 0·1004; diameter of cord 0·175 inch (4·44 millims.); temperature 18° C.

Maximum pressure 1041 atmospheres (6·83 tons per square inch); time required to reach the maximum pressure 0·028 second.

Time in seconds.	Pressure in atmospheres.	Time in seconds.	Pressure in atmospheres.
0·005	66	0·030	1031
0·010	192	0·035	1005
0·015	298	0·040	992
0·020	579	0·050	959
0·025	959	0·060	936
0·028	1041	0·070	909
		0·080	879
		0·090	860
		0·100	826
		0·200	645
		0·300	512
		0·400	423
		0·500	347
		0·600	298
		0·700	265
		0·800	235

TABLE IX.—(Record No. F 66.)

Cylindrical explosion vessel; charge uniformly distributed; gravimetric density 0·0753; diameter of cord 0·035 inch (0·89 millim.); temperature 19·0° C.

Maximum pressure 793 atmospheres (5·20 tons per square inch); time required to reach the maximum pressure 0·007 second.

Time in seconds.	Pressure in atmospheres.	Time in seconds.	Pressure in atmospheres.
0·001	26	0·008	787
0·002	102	0·009	783
0·003	195	0·010	777
0·004	324	0·015	760
0·005	453	0·020	750
0·006	658	0·025	721
0·007	793	0·030	701
		0·050	655
		0·100	539
		0·150	456
		0·200	380
		0·300	281
		0·400	212
		0·500	179
		0·600	152

TABLE X.—(Record No. F 67.)

Cylindrical explosion vessel ; charge all in half of cylinder farthest from the recorder ; gravimetric density 0·1004 ; diameter of cord 0·175 inch (4·44 millims.) ; temperature 19° C.

Maximum pressure 1035 atmospheres (6·79 tons per square inch) ; time required to reach the maximum pressure 0·026 second.

Time in seconds.	Pressure in atmospheres.	Time in seconds.	Pressure in atmospheres.
0·002	33	0·028	1031
0·004	66	0·030	1025
0·006	93	0·032	1018
0·008	152	0·034	1015
0·010	188	0·040	992
0·012	248	0·050	959
0·014	317	0·060	925
0·016	430	0·100	826
0·018	549	0·200	654
0·020	694	0·300	529
0·022	833	0·400	456
0·024	955	0·500	387
0·026	1035	0·600	340
		0·700	298
		0·800	258
		0·900	222

TABLE XI.—(Record No. F 68.)

Cylindrical explosion vessel ; charge all in one-sixth of cylinder farthest from the recorder ; gravimetric density 1·004 ; diameter of cord 0·175 inch (4·44 millims.) ; temperature 18·6° C.

Maximum pressure 1002 atmospheres (6·57 tons per square inch) ; time required to reach the maximum pressure 0·030 second.

Time in seconds.	Pressure in atmospheres.	Time in seconds.	Pressure in atmospheres.
0·002	33	0·032	1002
0·004	60	0·034	995
0·006	86	0·040	985
0·008	106	0·050	942
0·010	149	0·060	919
0·012	179	0·100	820
0·014	241	0·200	621
0·016	307	0·300	522
0·018	387	0·400	423
0·020	509	0·500	337
0·022	648	0·600	281
0·024	777		
0·026	879		
0·028	975		
0·030	1002		

TABLE XII.—(Record No. F 69.)

Cylindrical explosion vessel; charge all in one-sixth of cylinder near the recorder; gravimetric density 0.1004; diameter of cord 0.475 inch (12.07 millims.); temperature 18° C.

Maximum pressure 906 atmospheres (5.94 tons per square inch); time required to reach the maximum pressure 0.70 second.

Time in seconds.	Pressure in atmospheres.	Time in seconds.	Pressure in atmospheres.
0.010	43	0.075	906
0.015	73	0.080	896
0.020	106	0.090	869
0.025	145	0.100	850
0.030	188	0.200	671
0.035	235	0.300	562
0.040	374	0.400	456
0.045	539	0.500	364
0.050	678		
0.055	807		
0.060	879		
0.065	899		
0.070	906		

TABLE XIII.—(Record No. F 70.)

Cylindrical explosion vessel; charge all in one quarter of cylinder near the recorder; gravimetric density 0.0753; diameter of cord 0.035 inch (0.89 millim.); temperature 17.0° C.

Maximum pressure 764 atmospheres (5.01 tons per square inch); time required to reach the maximum pressure 0.007 second.

Time in seconds.	Pressure in atmospheres.	Time in seconds.	Pressure in atmospheres.
0.001	76	0.008	760
0.002	162	0.010	754
0.003	241	0.015	727
0.004	417	0.020	694
0.005	546	0.030	661
0.006	724	0.040	628
0.007	764	0.050	595
		0.100	489
		0.200	357
		0.300	265
		0.400	212
		0.500	175

TABLE XIV.—(Record No. F 71.)

Cylindrical explosion vessel; charge uniformly distributed; gravimetric density 0·1004; diameter of cord 0·175 inch (4·45 millims.); temperature 17·5° C.

Maximum pressure 1058 atmospheres (6·94 tons per square inch); time required to reach the maximum pressure 0·028 second; charge fired with 2 grammes of fine granulated powder.

Time in seconds.	Pressure in atmospheres.	Time in seconds.	Pressure in atmospheres.
0·002	26	0·035	1058
0·004	43	0·040	1051
0·006	83	0·050	1025
0·008	126	0·060	998
0·010	162	0·100	893
0·012	222	0·200	727
0·014	291	0·300	612
0·016	417	0·400	503
0·018	545	0·500	413
0·020	698	0·600	331
0·022	843	0·700	291
0·024	975	0·800	248
0·026	1038		
0·028	1058		
0·030	1058		

TABLE XV.—(Record No. F 72.)

Cylindrical explosion vessel; charge uniformly distributed; gravimetric density 0·1004; diameter of cord 0·035 inch (0·89 millim.); temperature 17·7° C.

Maximum pressure 1124 atmospheres (7·37 tons per square inch); time required to reach the maximum pressure 0·0050 second; charge fired with 2 grammes of fine granulated powder.

Time in seconds.	Pressure in atmospheres.	Time in seconds.	Pressure in atmospheres.
0·001	208	0·006	1124
0·002	519	0·007	1107
0·003	807	0·010	1101
0·004	1025	0·015	1071
0·005	1124	0·020	1024
		0·030	992
		0·040	959
		0·050	925
		0·100	810
		0·200	645
		0·300	529
		0·400	430
		0·500	363
		0·600	324
		0·700	281
		0·800	248

TABLE XVI.—(Record No. F 73.)

Cylindrical explosion vessel; charge uniformly distributed; gravimetric density 0·1505; diameter of cord 0·475 inch (12·07 millims.); temperature 18° C.

Maximum pressure 1633 atmospheres (10·71 tons per square inch); time required to reach the maximum pressure 0·058 second.

Time in seconds.	Pressure in atmospheres.	Time in seconds.	Pressure in atmospheres.
0·010	26	0·060	1633
0·020	76	0·065	1631
0·025	126	0·070	1587
0·030	244	0·080	1547
0·032	311	0·090	1504
0·034	413	0·100	1461
0·036	523	0·150	1322
0·038	665	0·200	1207
0·040	793	0·300	1051
0·042	1015	0·400	935
0·044	1174	0·500	843
0·046	1332	0·600	767
0·048	1461	0·700	688
0·050	1554	0·800	628
0·052	1603	0·900	579
0·054	1620		
0·056	1627		
0·058	1633		

TABLE XVII.—(Record No. F 74.)

Cylindrical explosion vessel; charge uniformly distributed; gravimetric density 0·1505; diameter of cord 0·175 inch (4·44 millims.); temperature 17·6° C.

Maximum pressure 1749 atmospheres (11·48 tons per square inch); time required to reach the maximum pressure 0·023 second.

Time in seconds.	Pressure in atmospheres.	Time in seconds.	Pressure in atmospheres.
0·002	33	0·028	1749
0·004	76	0·030	1742
0·006	99	0·035	1719
0·008	162	0·040	1692
0·010	225	0·050	1646
0·012	354	0·060	1610
0·014	545	0·070	1564
0·016	833	0·080	1527
0·018	1220	0·090	1494
0·020	1507	0·100	1455
0·022	1732	0·150	1316
0·023	1749	0·200	1197
0·024	1749	0·300	1041
		0·400	926
		0·500	853
		0·600	767
		0·700	701

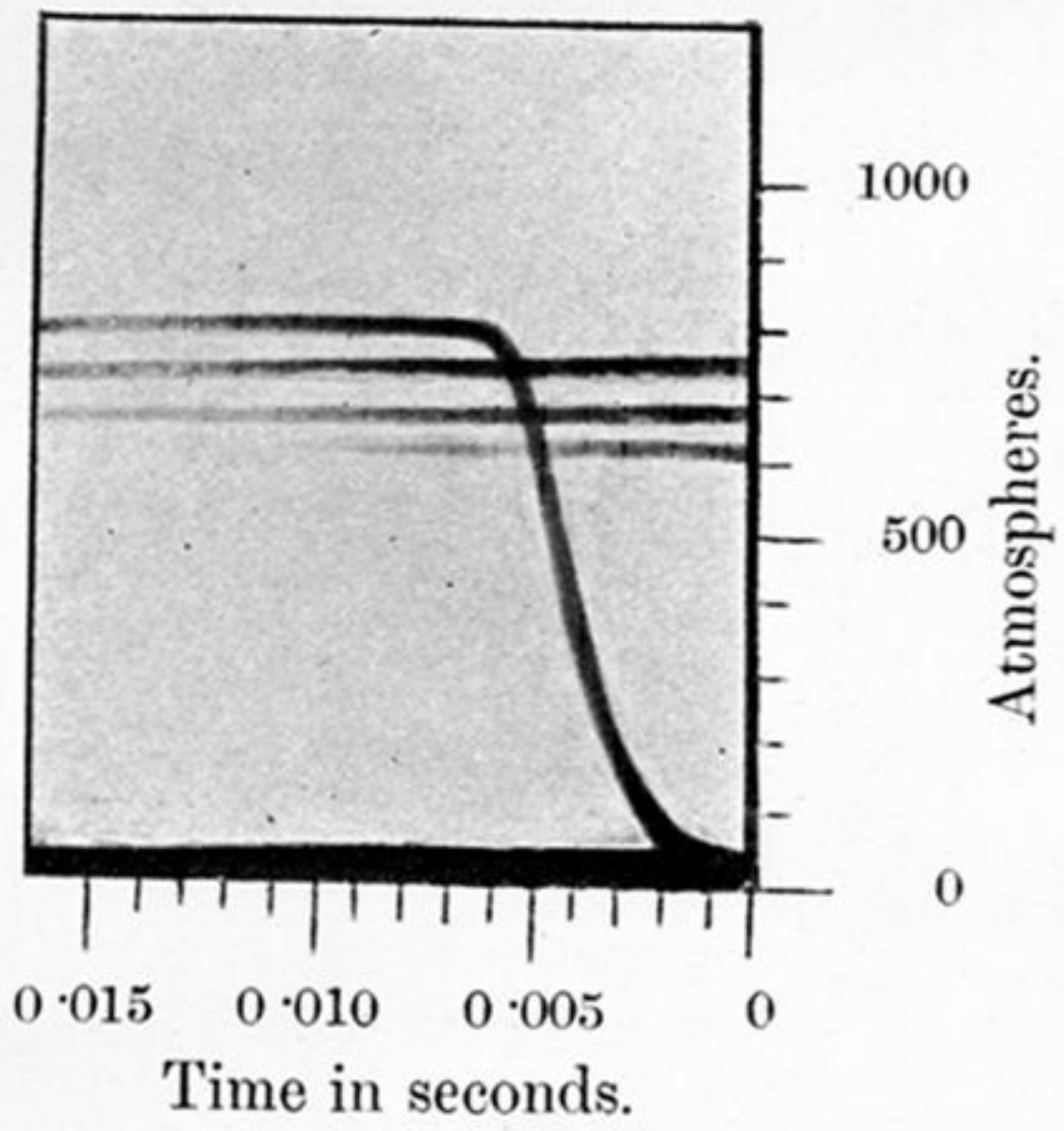

Fig. 1.

ordite 0.035 inch diameter.

gravimetric density = 0.0744.

charge uniformly distributed in spherical enclosure.

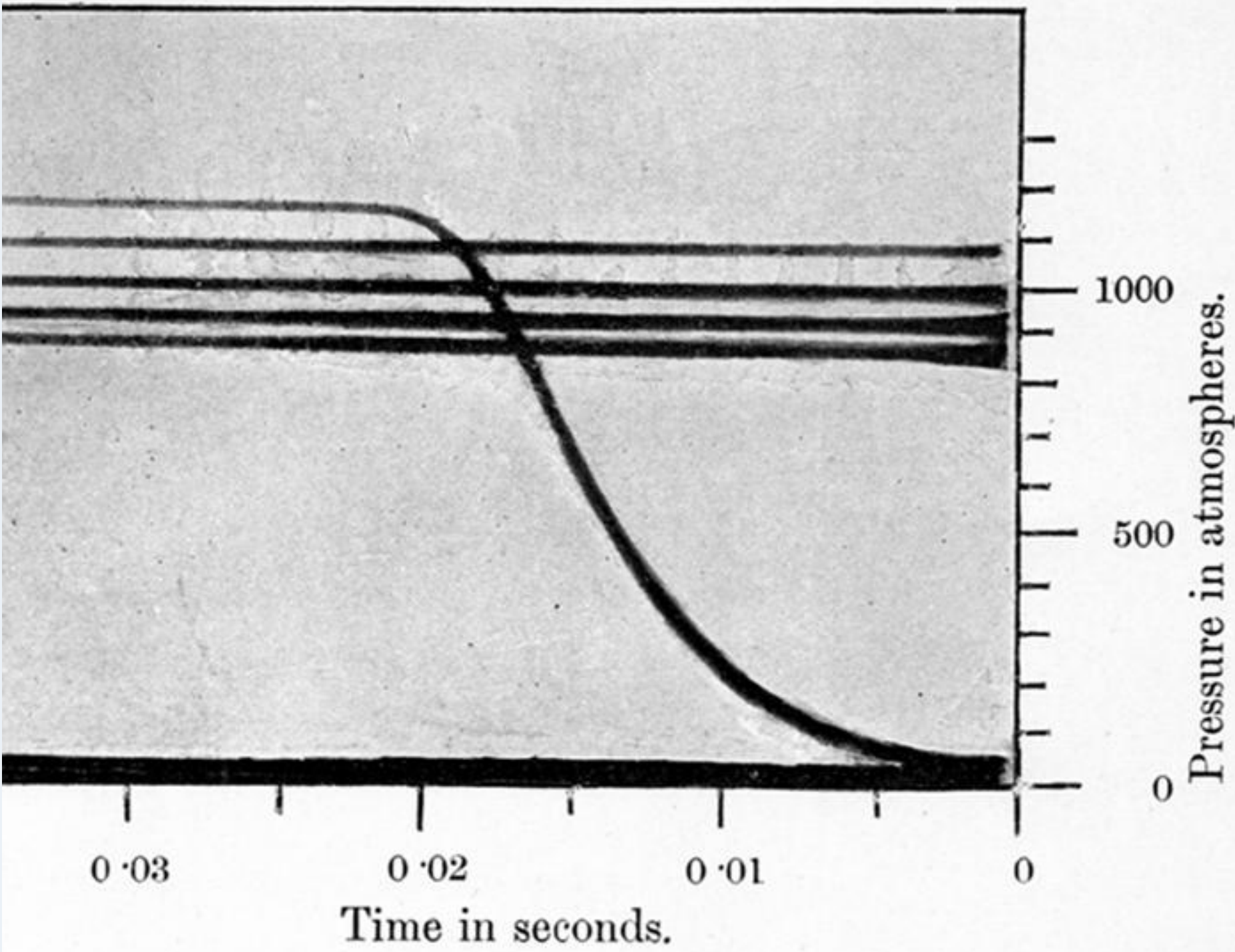

Fig. 2.

Cordite 0.175 inch diameter.

Gravimetric density = 0.099.

Charge uniformly distributed in spherical enclosure.

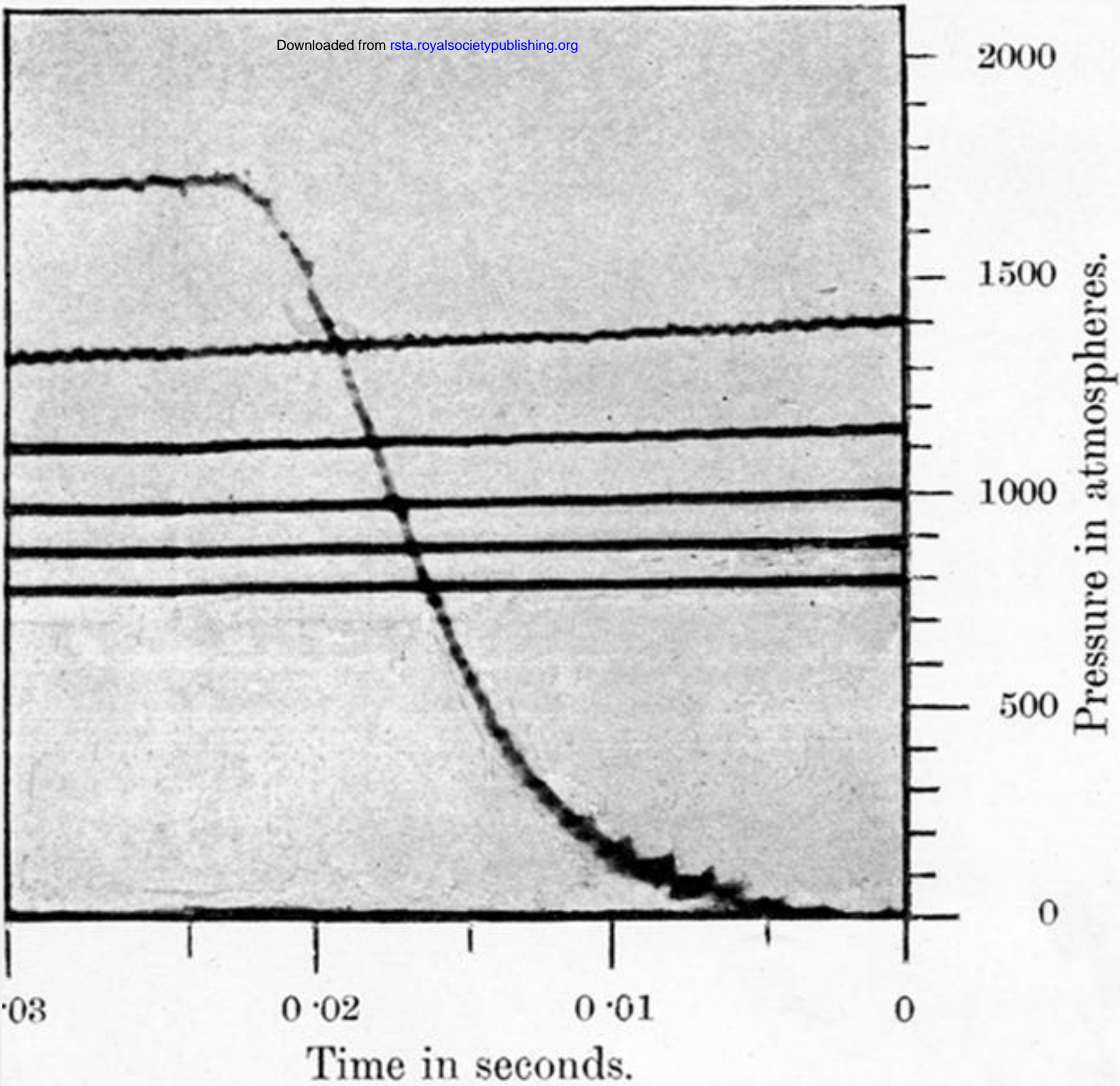

Fig. 3.

Cordite 0.175 inch diameter.

Gravimetric density = 0.15.

Charge uniformly distributed in cylindrical enclosure.

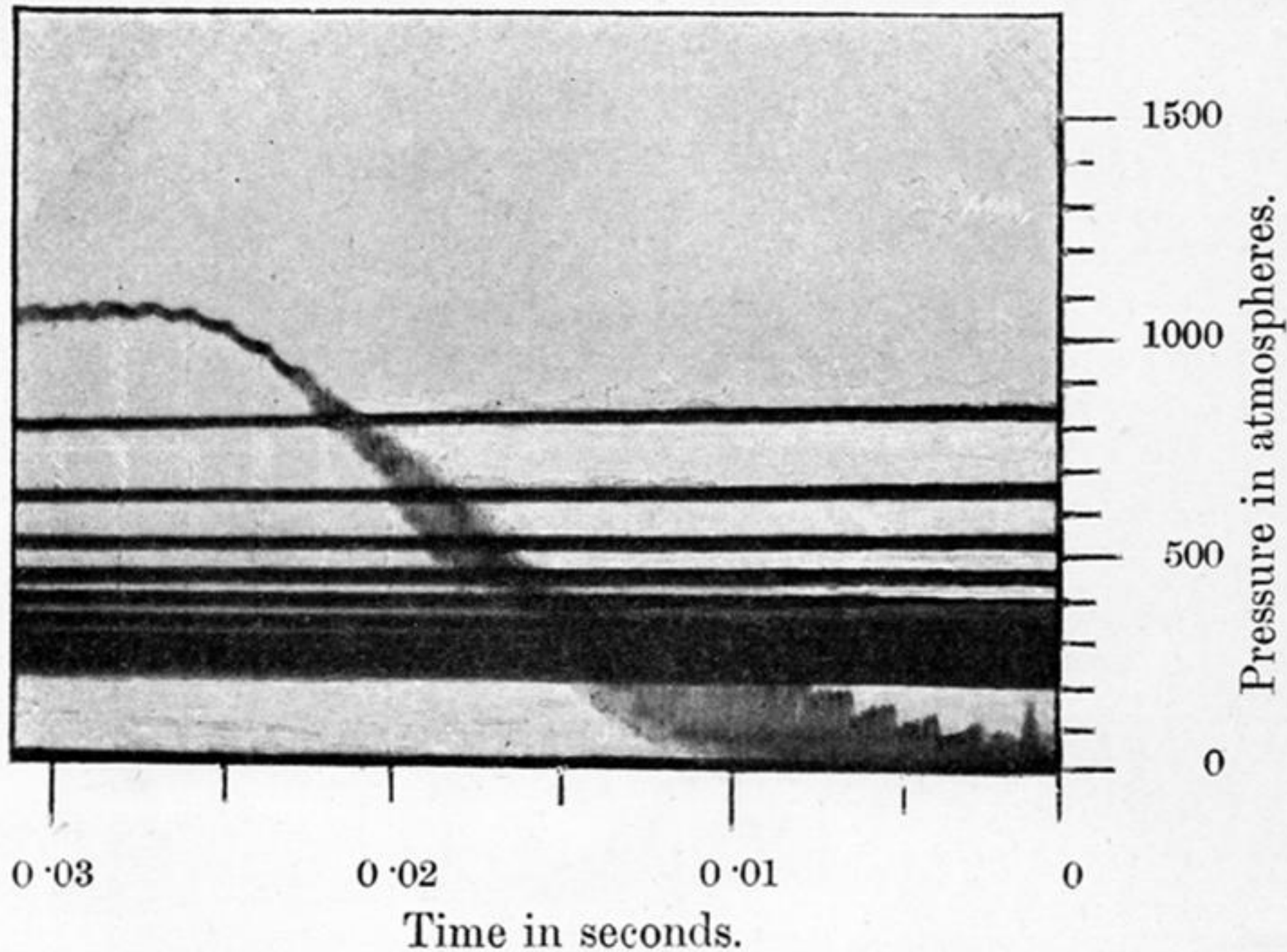

Fig. 4.

ordite 0.175 inch diameter.

gravimetric density = 0.10.

charge concentration in one half of the cylindrical enclosure.